

# Honeywell



Model **2054**

Model **2084**

# **ONE-HOUR COMBINATION FIRESAFES**

**with Key Lock**

**Read These Instructions Very Carefully!**

## Index

<b>Overview of Your Safe .....</b>	<b>Page 1</b>
<b>Opening &amp; Closing Your Safe.....</b>	<b>Page 2</b>
Opening The First Time	
Your Combination	
Opening With Combination Dial	
Closing & Locking The Safe	
<b>Additional Features: Shelves.....</b>	<b>Page 3</b>
<b>Additional Features: Bolt-Down Kit .....</b>	<b>Page 4</b>
<b>Customer Support .....</b>	<b>Page 6</b>
Your Safe's Unique Identification #'s	
How To Contact Us	
Ordering Replacement Keys	
Recovering Lost Combinations	
<b>Use, Care and Maintenance .....</b>	<b>Page 8</b>
<b>Limited Warranty .....</b>	<b>Page 9</b>

## For Your Protection

- Do not remove the serial number tag from the safe.
- Always store keys away from (AND NEVER INSIDE) safe.
- Record all safe identification #'s on I.D. Form (last page).
- Save this manual and NEVER keep it inside the safe.

## Congratulations!

Your new Honeywell Firesafe will provide years of safe and secure storage for valuables and important documents. Your safe has been built with the highest manufacturing standards to ensure maximum user satisfaction under a variety of conditions. We have also created this comprehensive and easy-to-use set of operation and installation instructions to give you complete understanding and confidence in the use of your safe.

## Package Contents

### All Models

- 1 – Honeywell Firesafe
- 1 – Operation & Installation Guide
- 2 – Companion Entry Keys

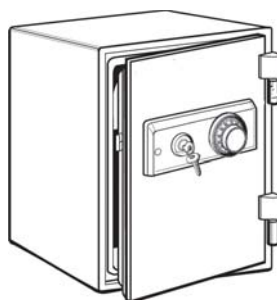

### Models 2054 (only)

- 1 – Bolt-Down Kit Including:
  - 1 – Mounting Template
  - 4 – Break-off Bolts
  - 4 – Washers



### Models 2054 (only)

- 1 – Removable Shelf



### Models 2084 (only)

- 1 – Adjustable Shelf
- 4 – Shelf Support Clips



### Important: DO NOT RETURN SAFE TO STORE

If you have difficulty opening the safe or any other questions pertaining to proper use, **DO NOT RETURN** your safe to the store. Please Contact Customer Service at 1-800-223-8566 (USA & Canada) for assistance.

# Opening & Closing Your Safe

## Opening The First Time

The dial is preset to the fourth (last) number in the combination. The safe door should open when you insert the Companion Entry Key (round top), turn to the right and pull the door open. The dial may move in transit, making it necessary to dial the combination before opening the first time. We recommend trying the following combination procedure with safe door open first.



## Your Combination

The combination for your safe can be found imprinted on the **inside back cover** of this manual. It is a preset 4 number sequence that is unique to your safe and cannot be changed. It is recommended that you keep this manual in a secure place, but **NEVER STORE THIS MANUAL INSIDE THE SAFE!**

## Opening With Combination Dial

1. Turn dial **RIGHT** (clockwise) three times to clear settings.
2. Start the dial on **0** (zero) to dial combination,
3. Turn dial **RIGHT**, passing first combination number **FOUR** (4) times and stop at number on fifth time around.
4. Turn dial **LEFT**, passing second combination number **TWO** (2) times and stop at number on third time around.
5. Turn dial **RIGHT**, passing third combination number **ONE** (1) time and stop at number on the second time around.
6. Turn dial **LEFT**, to the last combination number and STOP.
7. Insert the key in the lock and turn key **RIGHT** to open.

## Closing & Locking The Safe

1. When open, the key is turned right (the unlocked position).
2. Close the safe door and turn the key to the left.
3. Remove the key and spin the combination dial twice.

### Frequent Key-Only Access

When circumstances require frequent, quick and convenient access for limited periods during the day, you may choose to keep the combination positioned on the last number and lock only the keylock. However, the safe is not fully locked until spinning the dial.

### Important: REDUCED LEVEL OF SECURITY

The safe is **ONLY FULLY LOCKED** after turning key to the locked position and spinning the dial. For your security, we recommend always locking both the combination dial and key lock for the highest level of protection & security.

## Shelves

### Removable Shelf (Model 2054 only)

To remove the shelf, simply lift it up and tilt it on a sufficient angle to provide clearance for removal.

### Adjustable & Removable Shelves (Model 2084 only)

These models are designed with 5 position adjustable shelves to allow greater flexibility and further accommodate your particular security storage needs.

#### To Install:

Your Shelf and Shelf Support Clips have been shipped inside your safe and wrapped for protection from damage during shipping.

1. Remove Shelf and (4) Shelf Support Clips from protective wrapping.
2. Determine the desired position of your shelf and note the corresponding Support Guide Slots (2 on each side of interior walls) that are best suited to support the shelf in that position.
3. Install the (4) Shelf Support Clips in the same position on all four support guides.
4. Install shelf into position by placing it inside the safe (tilting if necessary) at a point above the desired position.
5. Once inside, lower it into position until resting on Shelf Support Clips.

#### To change the position of the shelf:

Simply remove the shelf and reposition the (4) shelf support clips by sliding them up and out of the support slots and reinstalling them into the new positions. Then reinstall the shelf as described above.

#### Important: REMOVING SHELF

If you remove the shelf, it is strongly recommended that you **DO NOT DISCARD** it. You may lay the shelf flat in the bottom of the safe to assure full flexibility in the future.

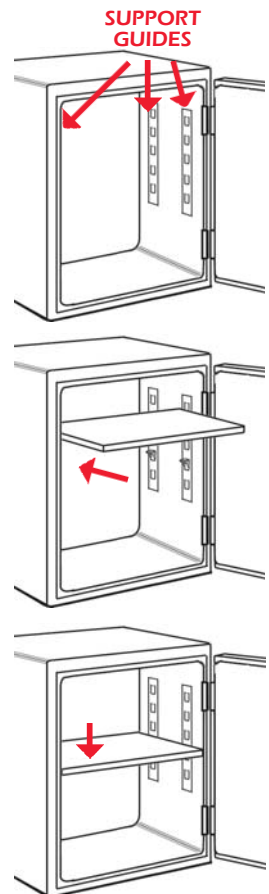

# Additional Features: Bolt-Down Kit

Models 2054 (only)

## Installing Your Safe

Certain models include a Bolt-Down kit with break-off bolts and a mounting template for permanent mounting to a flat surface. Once the safe is installed using the break-off bolts, it is permanent and cannot be easily removed.

## Tools Required

- 4 – Break-off Bolts (Supplied)
- 4 – Washers (Supplied)
- 1 – Mounting Template (Supplied)
- 1 – Drill
- 1 – Screwdriver

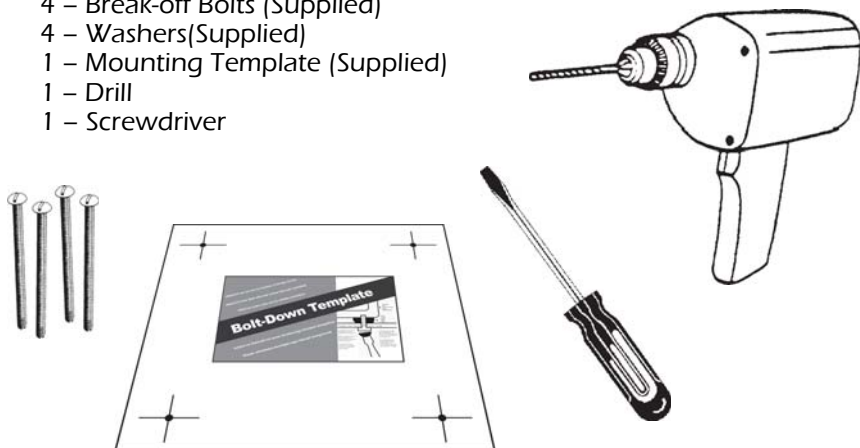

### Important: SECURING TO FLOOR

Many consumers prefer to bolt their safe to the floor to increase protection from theft and resistance to tipping. If your safe was manufactured with bolt down holes pre-drilled in the floor of the safe, bolting your safe to the floor may provide additional theft deterrence.

If you have **ANY QUESTIONS** about how to accomplish this, or are uncomfortable using the tools necessary to complete this project, please check with your local retailer, home center, or independent contractor.

Models 2054 (only)

## Installation Procedure

1. Choose a mounting location that is easily accessible from both above and below.
2. Carefully position the template on the location that you want to mount the safe.
3. Create the guide marks by pressing a sharp tool through the circles at the four corners of the template and into the mounting location.
4. Drill a hole (the diameter of the break-off bolt shaft) through each guide mark.

### Important: DON'T DRILL SAFE

Do not drill into the feet, bottom or any other part of safe! Doing so will **ELIMINATE THE FIRE PROTECTION** that has been designed into your safe and invalidate all stated warranties.

5. Before attaching the safe, you should check carefully that the 4 holes you have drilled match up precisely with the holes that have been pre-drilled in the bottom of the safe.

**Note:** On certain models, It may be necessary to remove the rubber foot pads that are screwed into the bolt-down holes at the factory.

6. Once you have confirmed that the holes are aligned and in the location you desire, install the break-off bolts and washers from underneath the mounting location (through the furniture or shelf), and into the pre-drilled holes in the safe.
7. Turn bolts until the screw heads break off.

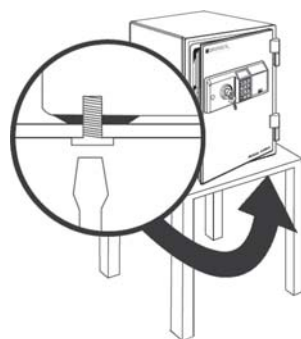
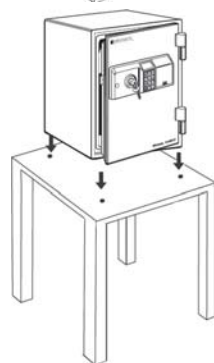
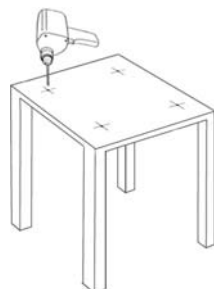

## Your Safe's Unique Identification Numbers

When contacting Customer Service, you should be prepared to supply some important information that specifically identifies your safe. This information is extremely important to assuring prompt and accurate assistance.

It is strongly recommended that you identify and record the following information in the "Identification Record" form located on the inside back cover of this manual.

### Model #

The Honeywell Home and Office Security Safes product line consists of many different models, each identified by a specific model #. Every model is manufactured with unique capabilities and features that may require specific solutions to a variety of difficulties that occasionally occur.

### Serial #

Each Individual safe is assigned a unique serial # when it is manufactured. This # allows our Customer Service Specialists to define many unique factors that will enable them to provide you with the best assistance.

### Key #

The key # is necessary to identify the specific configuration of the key and lock cylinder components of your safe. If a key becomes damaged or misplaced, the key # is absolutely required to provide you with a replacement key.

### Locating Serial # & Model #

Most Honeywell safes include a metallic or gray tag (with numbers and or letters) affixed to one of the external surfaces (most often on front or right side). This tag contains the serial # and selected models include a similar tag containing the model #. If your safe does not include a model # tag and you have not discarded the package, you can find the model # located near the bottom of the front label.

### Locating Key #

The key numbers are engraved on the keys and around the lock cylinder.

#### **Important: DO NOT REMOVE TAGS**

**PLEASE** do not remove the serial # or model # tags or any other identification tags or warning labels from the safe. You may need these numbers for future reference.

## How to Contact Us

**Phone: 1-800-223-8566**

Monday through Friday, 8:00 am to 4:00 pm Pacific Standard Time

**Email: [CustomerService@HoneywellSafes.com](mailto:CustomerService@HoneywellSafes.com).**

In addition to the required information regarding your safe, you must include the best time and proper telephone number to reach you during our normal Customer Service hours. You should receive a reply response via e-mail or phone within 24 business hours or the following business day.

**Mail: Attn: Customer Service Dept.**  
SISCO  
2835 E. Ana Street  
Rancho Dominguez, CA 90221

**Internet: [www.HoneywellSafes.com](http://www.HoneywellSafes.com)**

## Ordering Replacement Keys

If a key becomes misplaced or you would like additional keys, you may conveniently purchase them from our Customer Service department. You must supply the following information to assure accurate processing:

- **Name / Address / Telephone**
- **Safe model number / Serial number**
- **Type of keys requested (Companion or Override)**
- **Number of keys requested**
- **Key number (located on the lock)**

### Payment and Delivery

In the US, replacement keys are available for \$6.95 each and credit card orders are accepted by telephone and through our website. Checks or money orders are required for orders received by mail and should be made payable to "SISCO". Orders paid via money order or credit card typically ship within 72 hours. Orders placed with a personal or business check typically ship within 14 days.

## Recovering Lost Combinations

The following information is needed to provide you with your combination:

- **Name / Address / Telephone**
- **Safe model number / Serial number**
- **Key number (located on the lock)**

**NOTE:** If records are not on site, it may take up to 3 business days to respond.

Terms subject to change without notice.

## Appropriate Use of Your Safe

Honeywell fire safes protect paper records and many other valuables. Testing shows that the interior temperature remains below 350°F (177°C) for 1 or 2 hours (depending on model) during a fire up to 1700°F (927°C) when used properly. Your safe must be closed and latched in order to properly protect its contents from fire.

Your safe is guaranteed not to develop mildew from moisture originating in the safe's insulating material for five years. However, if the safe is stored in an area of high moisture content (such as near the ocean or in a tropical climate), moisture from the environment may become trapped inside the safe. If this applies to you, it is recommended that you open the safe on a regular basis to promote air circulation.

## Safe Care and Maintenance

When properly maintained, your safe will continue to provide security and protection of your valuables and important documents for many years to come. In order to ensure optimum performance of your safe, please follow these simple precautions:

**Clean Hands** - Do not attempt to dial your combination if your hands have excessive dirt, debris, or liquids on them. Under normal circumstances, it is not necessary to wash your hands before using the safe.

**Clean Safe** - To clean the outside surface of your safe, it is recommended that you use a mild cleaner (i.e. window cleaner) to avoid scratching or discoloring the surface. Do not use abrasive cleansers.

# Safe Identification Record

Model # \_\_\_\_\_

Serial # \_\_\_\_\_

Key # \_\_\_\_\_

## 4 Number Combination:

RIGHT FOUR (4) Turns  
and CONTINUE to:

LEFT TWO (2) Turns  
and CONTINUE to:

RIGHT ONE (1) Turn  
and CONTINUE to:

LEFT to:

# Limited Warranty

## LIFETIME AFTER FIRE REPLACEMENT GUARANTEE

If your Honeywell Firesafe is ever damaged by a fire, SISCO will replace it with a comparable model at no charge to the consumer. A photo of the damaged safe and a Fire Department report will be required as proof of loss. Freight on the replacement unit is not included in the guarantee and must be paid by the user.

## LIMITED WARRANTY

If your Honeywell safe fails to operate because of a manufacturing defect, any time up to five (5) years from the date of original purchase, we will, at our discretion, repair or replace the unit at no charge to the original owner provided you return the product, shipping prepaid, to SISCO, or to a service center or locksmith of our choice. Prior authorization must be obtained from SISCO in advance.

## WHAT IS NOT COVERED

This warranty does not apply if the product has been damaged by improper installation, neglect, accident, misuse, exposure to extremes of heat or humidity, terrorism, war, acts of God, or as a result of service or modification by other than an authorized Honeywell service center. Sisco is not responsible for any costs associated with removing or installing this product. SISCO is also not responsible for damage or loss of the contents of the safe nor for the unauthorized removal of contents.

This warranty does not apply to the finish of any metal portions of the product. No other expressed warranty is given. The repair or replacement of the product is your exclusive remedy. Any implied warranty of salability or fitness is limited to the duration of this written warranty. Some states do not allow limitations on how long an implied warranty lasts, so the above limitations may not apply to you. In no event shall SISCO be liable for consequential or incidental damages. Some states do not allow the exclusion or limitation of incidental or consequential damages, so the above limitation or exclusion may not apply to you. This warranty gives you specific rights and you may also have other rights which vary from state to state.

The Honeywell trademark for Home/ Office Safes is used with permission. Honeywell Safes are distributed exclusively by SISCO. Honeywell makes no representations or warranties with respect to this product or service, The Honeywell Trademark is used under license from Honeywell Intellectual Properties Inc. by SISCO.