

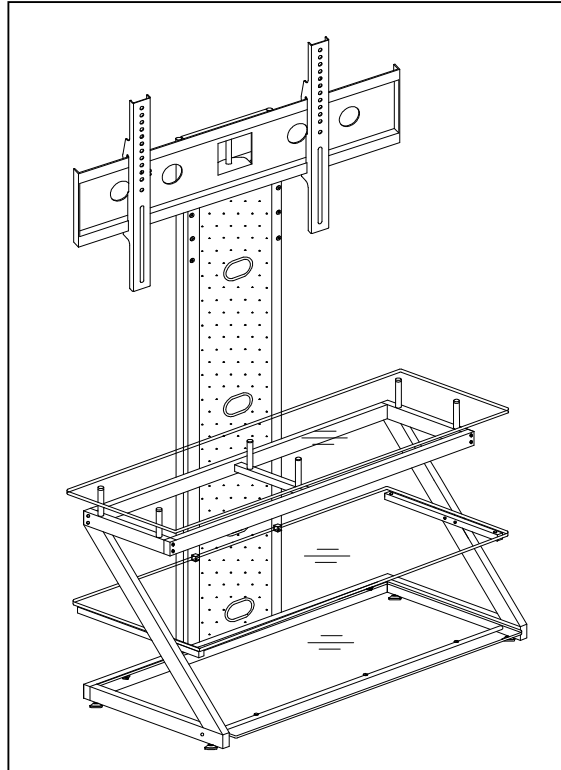

Portland Flat Panel TV Stand w/ Integrated Mount

ZLN # ZL23-44MU



⚠ DO NOT return to the store if parts are missing or damaged.

For Parts Replacements and Inquiries, please call us Toll-Free 1-888-736-2141 or E-mail

CustomerService@Z-LineDesigns.com.

To ensure a timely delivery, please include the following:

1. Full Name
2. Physical Address (Our primary carrier, FedEx, will NOT deliver to P.O. Boxes)
3. Phone Number
4. QC Number: SW _____
5. ZLN Number: ZL23-44MU
6. Part Number(s) or Letter(s)
7. Quantity
8. We also request that you please provide a brief description of the reason for your request.

**Our Customer Service Representatives will be available to assist you Monday – Friday 7:00 am to 3:30 pm
Pacific Standard Time (Except Holidays).**

Important

Estimated Assembly Time: 1hr 40min.

 TWO PEOPLE ARE NECESSARY FOR THE ASSEMBLY OF THIS PRODUCT.

Before you begin: Lay out all of the parts on a non-abrasive surface in order to identify and count prior to assembly. You will need the parts and hardware listed on pages 3 - 6 of this instruction manual as well as the tools shown below to assemble this unit.

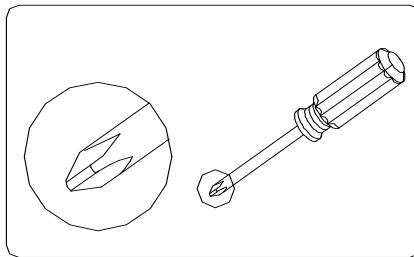















PHILLIPS HEAD SCREWDRIVER

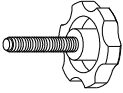

NOW YOU ARE READY TO BEGIN ACTUAL ASSEMBLY!

WARNING – Failure to follow these installation instructions or any other abuse, mistreatment, unreasonable use or neglect of the product shall constitute a waiver of all warranties, expressed and implied, and constitute a waiver of all claims of liability against Z-Lines Designs, Inc., its directors, officers, shareholders, parents, subsidiaries, affiliates, agents, customers and licensors, for any direct, indirect, special (including loss of revenue or income, pain and suffering, emotional distress, or similar damages), incidental, punitive, or consequential damages arising out of or resulting from the improper installation, abuse, mistreatment, unreasonable use or neglect regardless of whether such damages arise in contract, tort, under statute, in equity, at law, or otherwise.











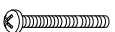

HARDWARE IDENTIFICATION

A		FLOOR LEVELER (FL81550)	4 PCS
B		6x38x16mm ALLEN BOLT (AB63816BL)	14 PCS
C		8x25x12mm ALLEN BOLT (AB82512BL)	4 PCS
D		6x40x10mm ALLEN BOLT (AB64010BL)	8 PCS
E		6x35x10mm ALLEN BOLT (AB63510BL)	1 PC
F		6x10x10mm ALLEN BOLT (AB61010BL)	2 PCS
G		TUBE NUT (TN81616BL)	4 PCS
H		4x8x8mm MACHINE SCREW (MS488BL)	4 PCS
I		4x10x8mm MACHINE SCREW (MSFH4108BL)	2 PCS
J		SHELF PIN BRACKET	2 PCS
K		SHELF PIN SCREW W/RUBBER STOPPER	2 PCS
L		PLASTIC GLASS SUPPORT	10 PCS
M		4mm ALLEN WRENCH (AW4BL)	1 PC
N		ADJUSTER	2 PCS
ZM		5mm ALLEN WRENCH (AW5BL)	1 PC
ZN		NAME PLATE	1 PC

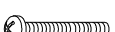

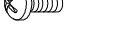
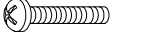

*Extra hardware is enclosed for your convenience.

THE BELOW PARTS ARE PRE-ASSEMBLED AND ARE LISTED AS A REFERENCE ONLY.			
O		WIRE MANAGEMENT COVER	4 PCS
P		ROUNDED BACK PANEL END CAP	4 PCS
Q		QUADRATE BACK PANEL END CAP	4 PCS

MOUNTING HARDWARE IDENTIFICATION

R		RUBBER PAD	4 PCS
S		SMALL SPACER	4 PCS
T		LARGE SPACER	4 PCS
U		DUAL-HOLE WASHER	4 PCS
V		4x15x8mm MACHINE SCREW (MS4158BL)	4 PCS
W		4x35x8mm MACHINE SCREW (MS4358BL)	4 PCS
X		4x54x8mm MACHINE SCREW (MS4548BL)	4 PCS
Y		5x15x8mm MACHINE SCREW (MS5158BL)	4 PCS
Z		5x35x8mm MACHINE SCREW (MS5358BL)	4 PCS
ZA		5x54x8mm MACHINE SCREW (MS5548BL)	4 PCS
ZB		6x15x10mm MACHINE SCREW (MS61510BL)	4 PCS
ZC		6x35x10mm MACHINE SCREW (MS63510BL)	4 PCS
ZD		6x54x10mm MACHINE SCREW (MS65410BL)	4 PCS
ZE		8x15x14mm MACHINE SCREW (MS81514BL)	4 PCS
ZF		8x35x14mm MACHINE SCREW (MS83514BL)	4 PCS
ZG		8x54x14mm MACHINE SCREW (MS85414BL)	4 PCS

WALL MOUNTING KIT

ZH		4.5x10x8mm MACHINE SCREW (MS45108BL)	2 PCS
ZI		4x25x6mm WOOD SCREW (RHWS4256BL)	2 PCS
ZJ		PLASTIC SOCKET	2 PCS
ZK		MOUNTING TAB	4 PCS
ZL		PLASTIC MOUNTING STRAP	2 PCS

PARTS IDENTIFICATION-1

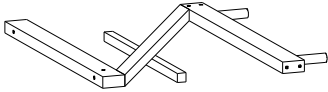
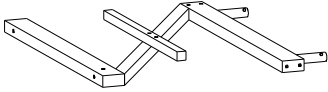
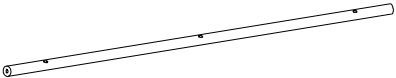
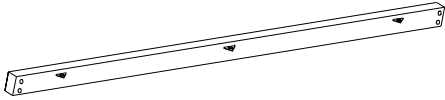
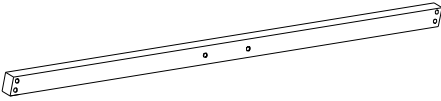
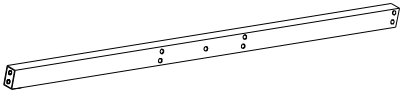
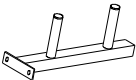
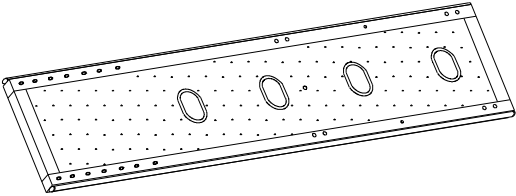
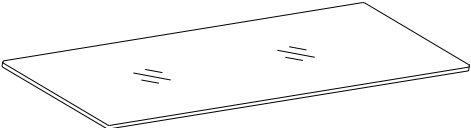
①		LEFT SIDE FRAME	1 PC
②		RIGHT SIDE FRAME	1 PC
③		LOWER FRONT CROSSBAR	1 PC
④		LOWER BACK CROSSBAR	1 PC
⑤		UPPER FRONT CROSSBAR	1 PC
⑥		UPPER BACK CROSSBAR	1 PC
⑦		CONNECTER	1 PC
⑧		BACK PANEL	1 PC
⑨		LOWER GLASS SHELF	1 PC

PARTS IDENTIFICATION-2

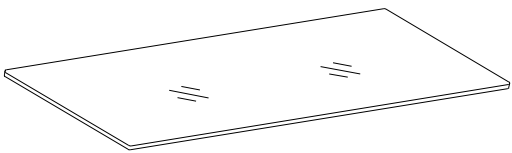
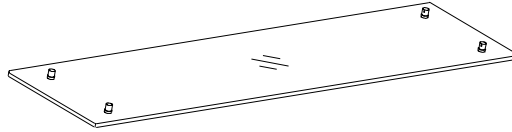
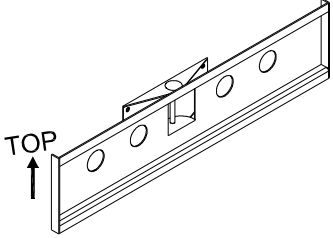
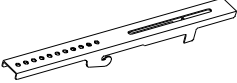
⑩	 A rectangular glass shelf with two small rectangular cutouts near the center.	MIDDLE GLASS SHELF	1 PC
⑪	 A rectangular glass shelf with four small rectangular cutouts, one near each corner.	TOP GLASS SHELF	1 PC
⑫	 A rectangular panel with a central cutout and four circular holes. An arrow labeled "TOP" points to the top edge.	UPPER MOUNTING PANEL	1 PC
⑬	 A long, narrow rail with a series of small circular holes along its length and a small notch at one end.	MOUNTING RAIL	2 PCS

ASSEMBLY INSTRUCTION

STEP 1



Connect (A) Floor Levelers to (1) Left Side Frame and (2) Right Side Frame.

STEP 2

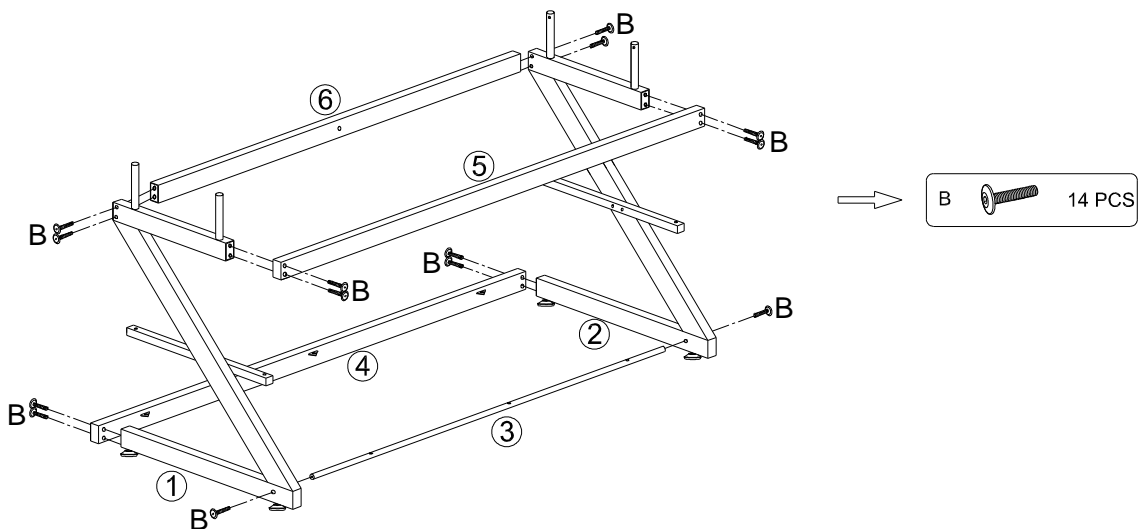

DO NOT FULLY TIGHTEN ALLEN BOLTS UNTIL STEP 5.

1. Connect (3) Lower Front Crossbar to (1) Left Side Frame and (2) Right Side Frame with (B) 6 x 38 x 16mm Allen Bolts.

***NOTE: Make sure the holes to attach (L) Plastic Glass Supports (in Step 4) face UPWARD.**

2. Attach (4) Lower Back Crossbar and (6) Upper Back Crossbar to (1) Left Side Frame and (2) Right Side Frame with (B) 6 x 38 x 16mm Allen Bolts.

***NOTE: Make sure the holes to connect (8) Back Panel (in Step 3) face the BACK and the Glass Support Ledges located on (4) Lower Back Crossbar are closer to the TOP.**

3. Now attach (5) Upper Front Crossbar to (1) Left Side Frame and (2) Right Side Frame with (B) 6 x 38 x 16mm Allen Bolts.

***NOTE: Make sure the holes to connect (7) Connector (in Step 3) face the INSIDE of the unit.**

STEP 4

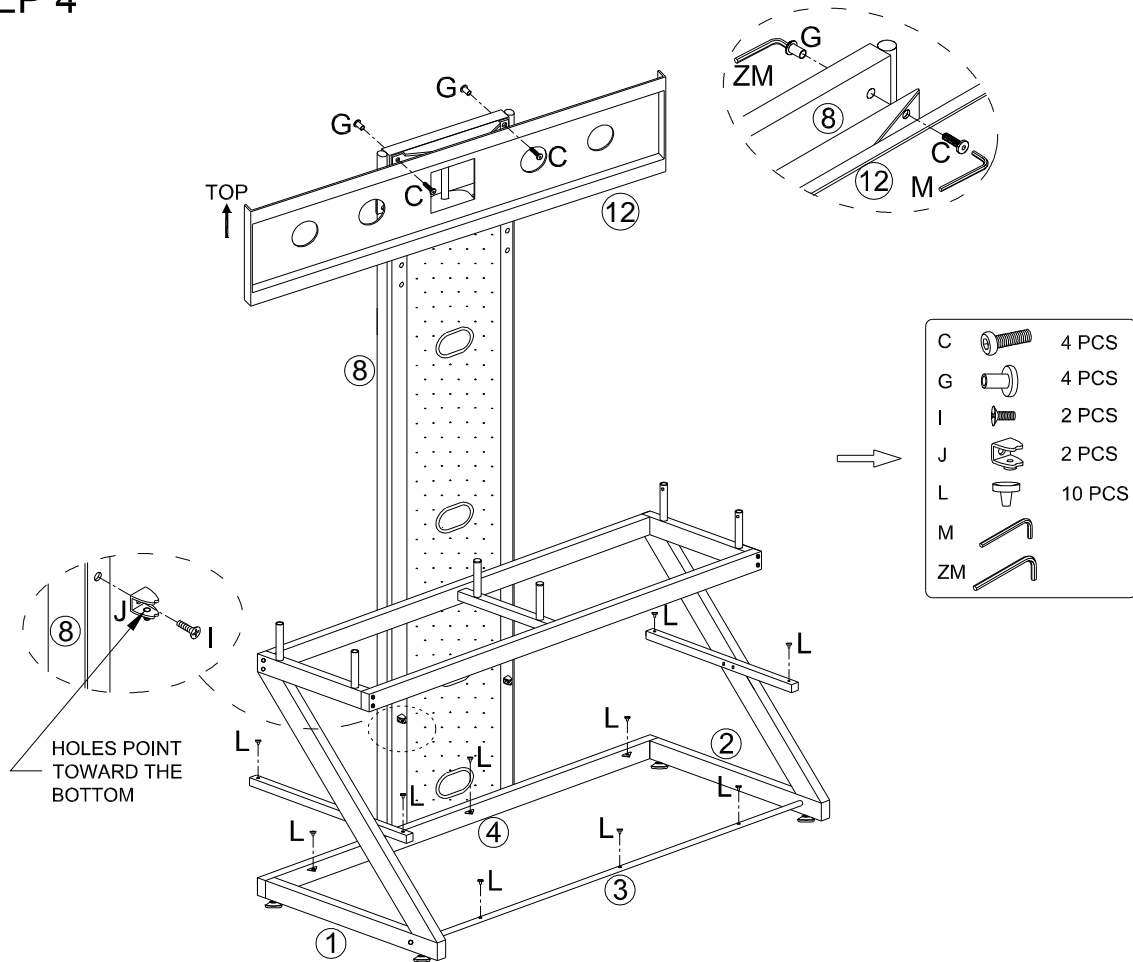
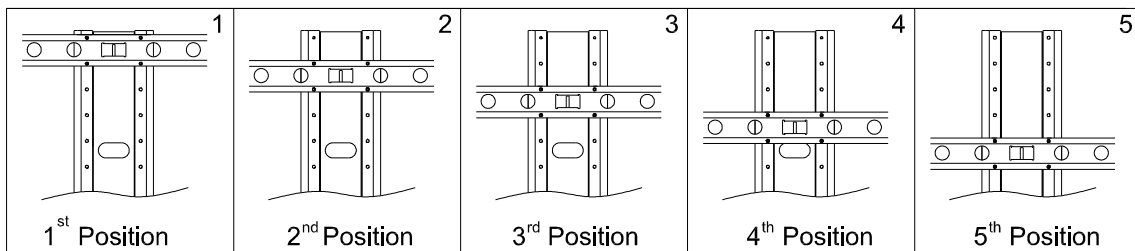

FIGURE 1



***NOTE: There are FIVE different positions for the Arms as shown in Figure 1. Please decide your preferred height at this time.**

1. Attach (J) Shelf Pin Brackets to (8) Back Panel with (I) 4 x 10 x 8mm Machine Screws. **FULLY TIGHTEN.**

***NOTE: Make sure the Holes to connect (K) Shelf Pin Screw (in Step 5) face the BOTTOM.**

2. Insert (L) Plastic Glass Supports into the holes provided on (1) Left Side Frame, (2) Right Side Frame, (3) Lower Front Crossbar, and (4) Lower Back Crossbar as shown.

3. Now attach (12) Upper Mounting Panel to (8) Back Panel in the desired position with (C) 8 x 25 x 12mm Allen Bolts and (G) Tube Nuts as shown.

4. **Fully tighten** by using (M) 4mm Allen Wrench to tighten (C) 8 x 25 x 12mm Allen Bolts in one direction and (ZM) 5mm Allen Wrench to tighten (G) Tube Nuts in the other direction.

STEP 5

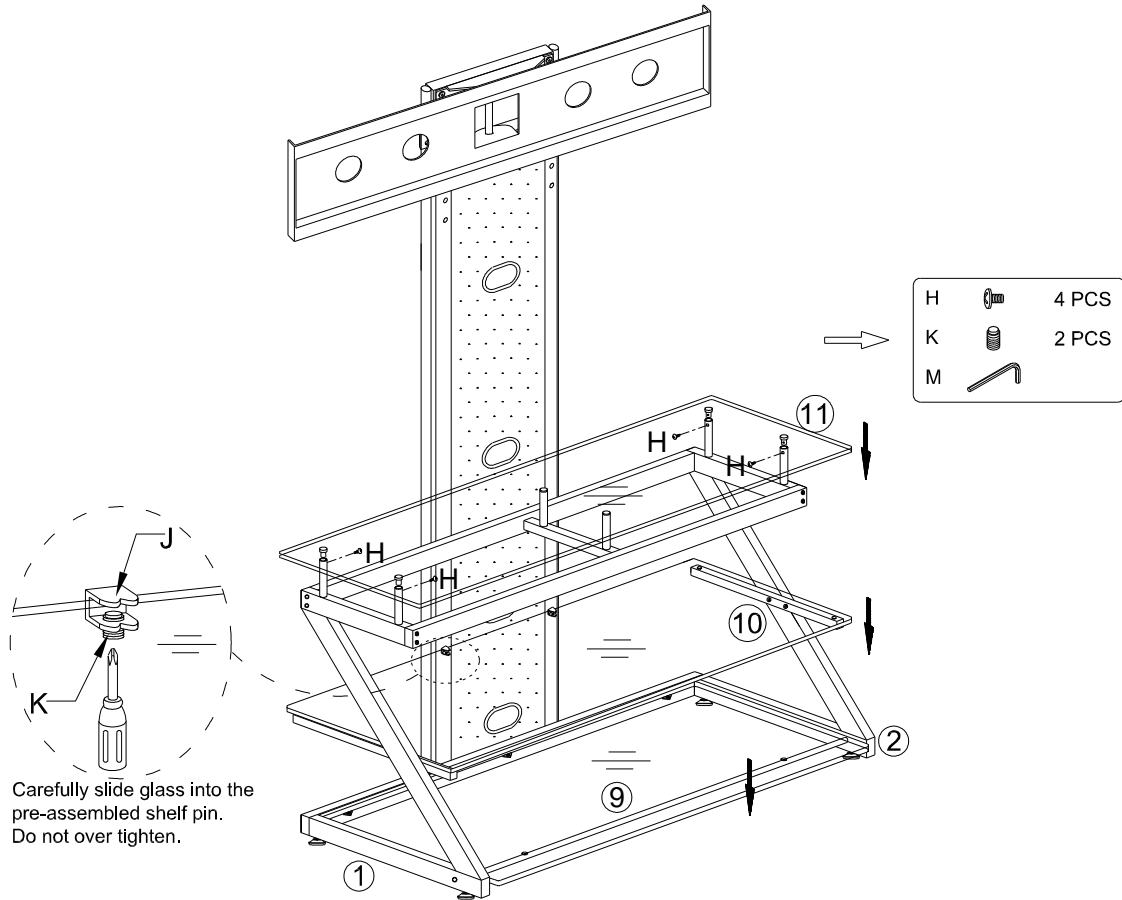

1. Carefully set (11) Top Glass Shelf in place as shown and secure using (H) 4 x 8 x 8mm Machine Screws as shown. **FULLY TIGHTEN.**

2. FULLY TIGHTEN ALL ALLEN BOLTS FROM STEPS 2 AND 3 AT THIS TIME.

3. Now carefully set (10) Middle Glass Shelf and (9) Lower Glass Shelf in place, making sure (10) Middle Glass Shelf fits into the Shelf Pin Brackets (attached in Step 4). Secure using (K) Shelf Pin Screws, making sure the Rubber Stoppers face the GLASS.

STEP 6

⚠ PAY EXTRA CARE AND ATTENTION TO THIS STEP. MAKE SURE THE APPROPRIATE MOUNTING HARDWARE IS BEING USED PROPERLY. ⚠

- Carefully lay your Plasma/Flat Panel TV on its FACE on a non-abrasive surface, making sure to lay padding underneath it so as not to damage the screen.
- BEFORE YOU CONTINUE YOU WILL NEED TO DETERMINE THE DIAMETER OF THE NECESSARY MACHINE SCREW FOR YOUR TV. Hand-thread each diameter Machine Screw until you find the size that fits properly. STOP IMMEDIATELY IF THERE IS ANY RESISTANCE.
- Once you have established the correct diameter, you will need to select the appropriate length.

FLAT BACK TV: You will only need to use the 15mm long Machine Screws. Please discard the 35mm and 54mm Machine Screws and Spacers and continue to Step 6A at the bottom of this page.

ROUNDED, INSET OR OBSTRUCTED BACK TV: The Machine Screws that are 35mm and 54mm in length are to be used with the provided Spacers on a Rounded Back TV. Please continue to Step 6B on the next page.

SCREW DIAMETER/HOLE SIZE REFERENCE						
	HARDWARE IDENTIFICATION	PICTURE	THREAD DIAMETER (mm)	LENGTH (mm)	THREAD DIAMETER (mm)	DUAL-HOLE WASHER/SPACER POSITIONING
M4	V		4	15	8	SMALL HOLE (6mm)
	W		4	35	8	
	X		4	54	8	
M5	Y		5	15	8	
	Z		5	35	8	
	ZA		5	54	8	
M6	ZB		6	15	10	LARGE HOLE (8mm)
	ZC		6	35	10	
	ZD		6	54	10	
M8	ZE		8	15	14	
	ZF		8	35	14	
	ZG		8	54	14	

STEP 6A - FLAT BACK

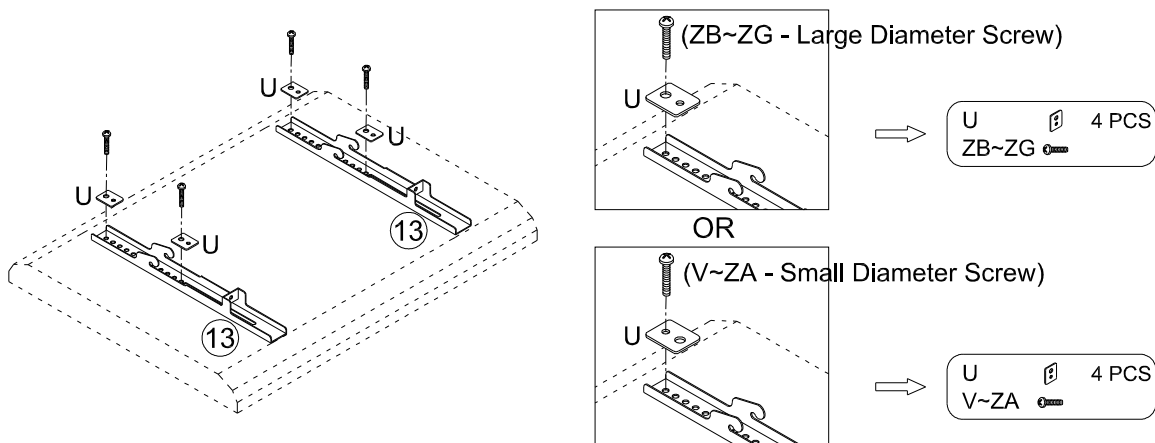



- Place (13) Mounting Rails in the appropriate position, making sure they are CENTERED on the back of the TV and LEVEL with one another.
- Now Insert Machine Screws through the appropriate holes located on (U) Dual-Hole Washers (see Screw Diameter/Hole Size Reference above), next though (13) Mounting Rails, and then into the TV.

***NOTE: the position of the Mounting Brackets and Hardware will be determined by the type of TV that you have. These diagrams are not designed to show the exact positioning, they are only to be used as a guide.**

SECURE MACHINE SCREWS FULLY BUT DO NOT OVER-TIGHTEN.

STEP 6B - ROUNDED BACK

SCREW LENGTH/SPACER GUIDE			
PICTURE			
SCREW LENGTH	15mm	35mm	54mm
SPACER S(5/8")/T(3/4")	N/A	S <u>or</u> T	S <u>and</u> T

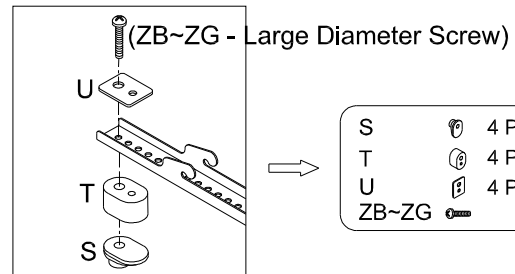
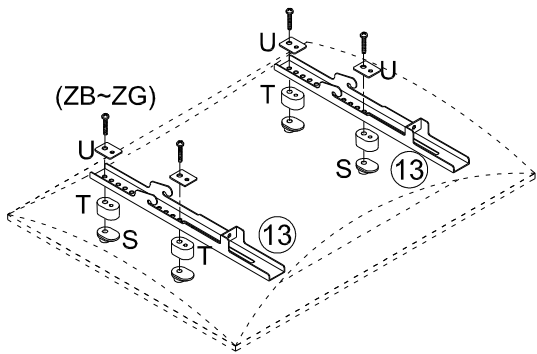

OR

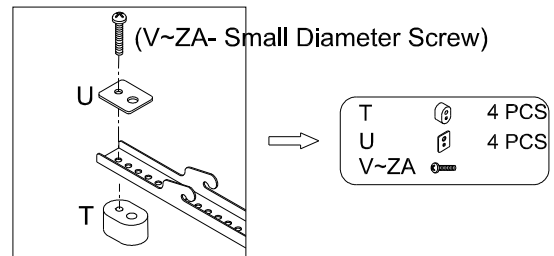
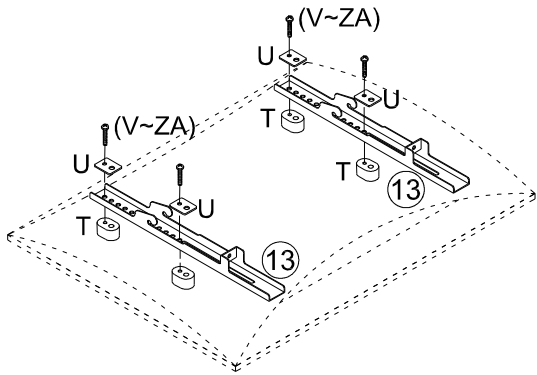

4. Place (S) Small Spacers and/or (T) Large Spacers and (13) Mounting Rails in the appropriate position, making sure the Rails are CENTERED on the back of the TV and LEVEL with one another.

5. Now Insert Machine Screws through the appropriate holes located on (U) Dual-Hole Washers (see Screw Diameter/Hole Size Reference on the previous page), though (13) Mounting Rails, through (S) Small Spacers and/or (T) Large Spacers, and then into the TV.

***NOTE: the position of the Mounting Brackets and Hardware will be determined by the type of TV that you have. These diagrams are not designed to show the exact positioning, they are only to be used as a guide.**

SECURE MACHINE SCREWS FULLY BUT DO NOT OVER-TIGHTEN.

STEP 7

TWO PEOPLE ARE NECESSARY FOR THE COMPLETION OF THIS STEP.

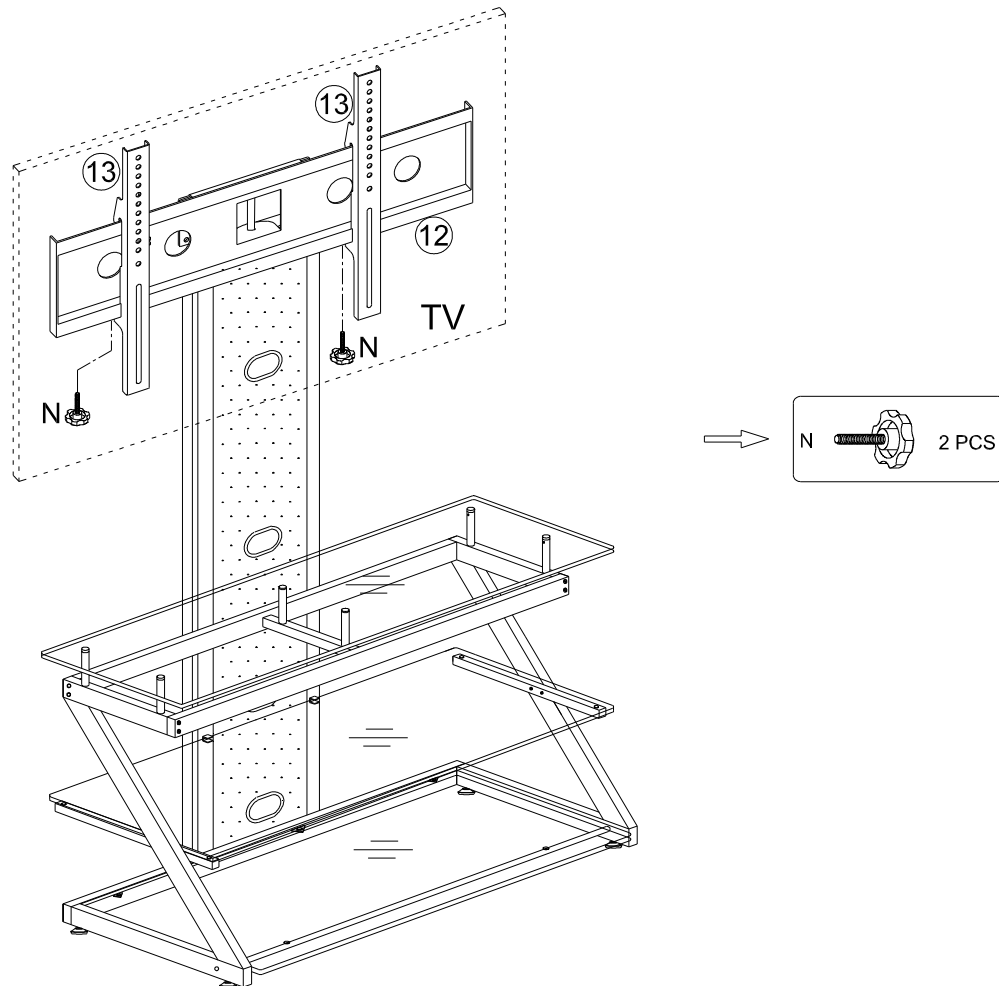

1. Carefully lift your Plasma/Flat Panel TV with attached Mounting Rails and set into position on (12) Upper Mounting Panel as shown.

***NOTE: YOU WILL NEED A SECOND PERSON TO HOLD YOUR PLASMA/FLAT PANEL TV IN PLACE UNTIL IT HAS BEEN FULLY SECURED.**

2. Once (13) Mounting Rails are in position and centered on (12) Upper Mounting Panel, secure the BOTTOMS with (N) Adjusters. **FULLY TIGHTEN.**

**CONGRATULATIONS, YOUR Z-LINE DESIGNS PORTLAND FLAT PANEL TV STAND
W/INTEGRATED MOUNT IS NOW COMPLETE!**



CAUTION:

- YOU MUST RETIGHTEN BOLTS AFTER THE TV HAS BEEN HUNG AND THE UNIT IS IN ITS FINAL POSITION IN ORDER TO PREVENT POTENTIAL DAMAGE.
- WE STRONGLY RECOMMEND RETIGHTENING BOLTS PERIODICALLY AS WELL AS ANY TIME THE UNIT IS MOVED.

In the event that your TV tilts downward slightly, please insert the provided (R) Rubber Pads over (13) Mounting Rails as shown.

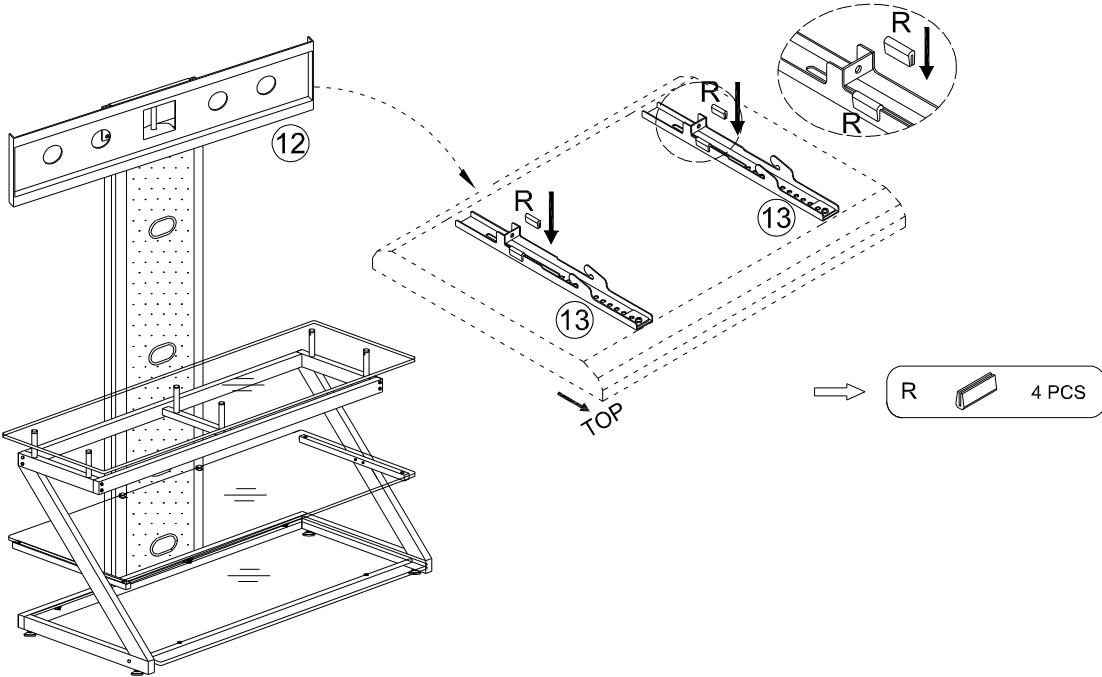

OR

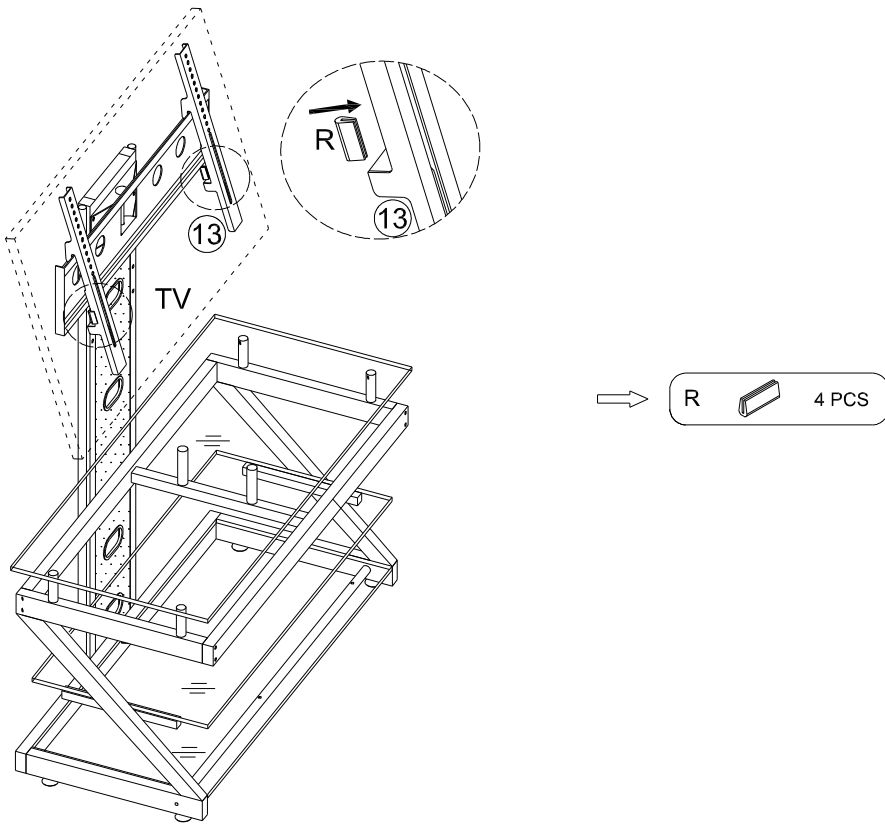

FIX PRODUCT ONTO THE WALL

***NOTE: WE RECOMMEND THAT YOU ATTACH THE PRODUCT TO YOUR WALL AS A SAFETY PRECAUTION.**

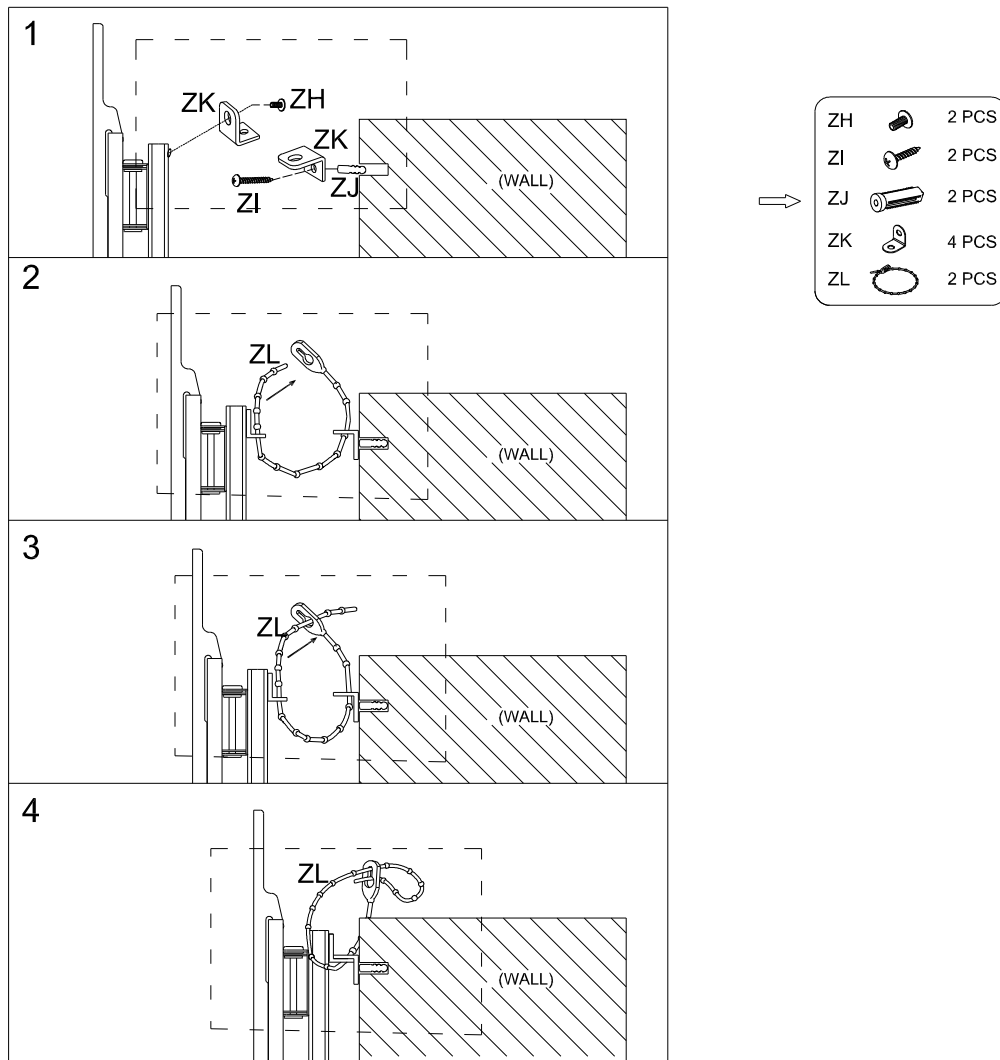

1. Attach (ZK) Mounting Tabs to the BACK of the Product with (ZH) 4.5 x 10 x 8mm Machine Screws, making sure the Tabs extend DOWNWARD as shown.

2. Drill 2 (Two) holes in your wall approximately 2" (Two Inches) BELOW the corresponding positions of (ZK) Mounting Tabs and insert (ZJ) Plastic Sockets as shown.

***NOTE: You may need to tap LIGHTLY with a rubber mallet.**

3. Attach (ZK) Mounting Tabs to (ZJ) Plastic Sockets with (ZI) 4 x 25 x 6mm Wood Screws, making sure the Tabs extend UPWARD.

4. Now connect the corresponding (ZK) Mounting Tabs with (ZL) Plastic Mounting Straps and tighten as desired before locking in place.

DIMENSIONS

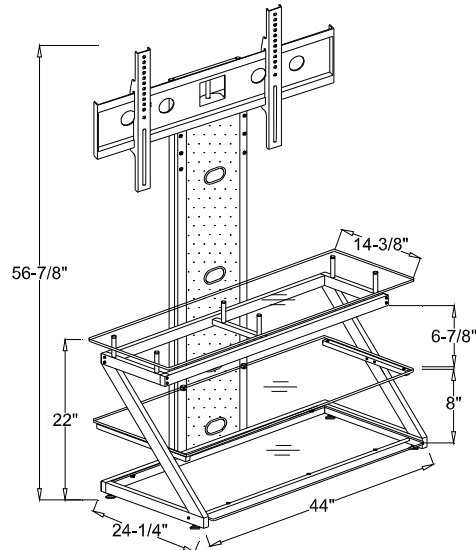

Product Size: 44"(W)x24-1/4"(D)x56-7/8"(H)

MAXIMUM WEIGHT CAPACITIES

Remove the backing and adhere the name plate to the Top Glass Shelf. Carefully consider placement since adhesive is permanent

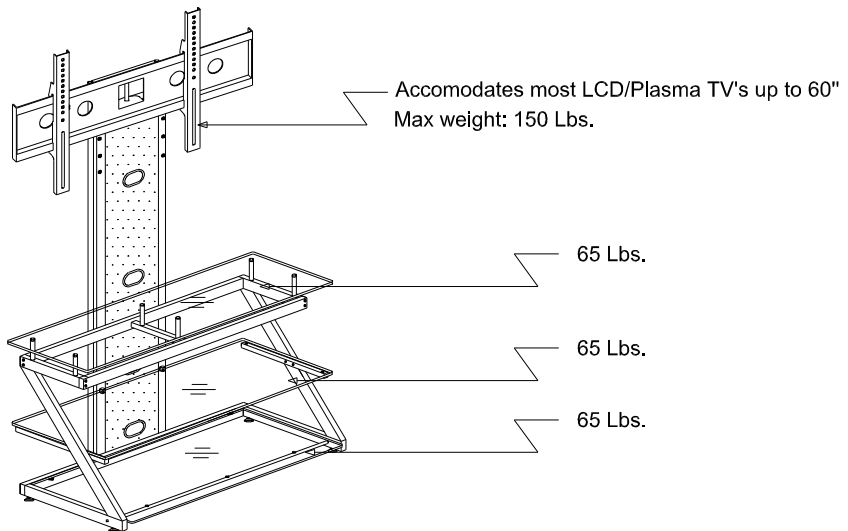

⚠ CAUTION: This product is intended to hold the Maximum Weight (EVENLY DISTRIBUTED) indicated. Exceeding the Maximum Weight will result in instability and may cause possible injury.

If the glass is chipped or broken stop using the product and consult the manufacturer or supplier.

* GLASS CAUTION:

- DO NOT place very hot or very cold items on the glass surface(s) unless adequately thick table mats are used to prevent such items from coming into contact with the glass.
- DO NOT sit or stand on the glass surface(s).
- DO NOT use the glass as a chopping surface.
- DO NOT strike the glass with hard or pointed items.
- When cleaning the glass, use a liquid glass surface cleanser and a soft cloth; DO NOT use harsh powders or any other abrasive substances as they will scratch the glass.



Creating beauty, Manufacturing great value!



Limited Lifetime Warranty

Thank you for purchasing a Z-Line Designs product. We promise to repair or replace any Z-Line Designs product or component that may have any defects in material or workmanship for as long as you, the original purchaser, own it. This warranty is subject to the provisions below. Z-Line Designs' sole obligation and purchasers' exclusive remedy pursuant to these warranties are limited to replacement at Z-Line Designs sole discretion. There are no other warranties except as expressly set forth below, either expressed or implied, including any warranty of merchantability for any particular purpose.

The word "defects" in this warranty is defined as imperfections that impair the service, function or effectiveness of the product.

FIVE YEARS:

Glides, casters and user-adjustable work surface mechanisms, laminates, veneer finishes, and other materials which cover your Z-Line Designs product.

INFORMATION ON COLOR VARIATIONS & FINISHES:

Some natural variations occurring in wood or other natural materials are inherent to their character, and thus can not be avoided. Therefore they are not considered to be defects. Z-Line Designs does not warrant the color-fastness or matching of colors, grains, textures or other such materials. Customers' own materials selected by and used at the request of a user are therefore not warranted by Z-Line Designs.

LIMITATIONS INVOLVING MATERIALS & COMPONENTS:

The materials and all components listed below are covered according to the following schedule from the date of sale to the original purchaser.

EXCLUSIONS:

This warranty does not apply to: damage caused by the carrier, modifications to the product, or attachments to the product not approved by Z-Line Designs, non-standard materials selected by and used at the request of a user, and products that were not installed, used or maintained in accordance with product instructions and warnings. Nor shall Z-Line Designs have any responsibility for incidental or consequential damages resulting from the breach of this Warranty, including but not limited to inconvenience, rental or purchase of replacement products, loss of profits or commercial loss. Some states do not allow the exclusion or limitation of incidental or consequential damages so the above limitation or exclusion may not apply to you. This warranty gives you specific legal rights and you may also have other rights, which may vary from state to state. This warranty applies only to products sold within the United States of America and the Commonwealth of Canada.

TO OBTAIN SERVICE FROM THIS WARRANTY:

Your Z-Line Designs' dealer is our mutual partner in supporting your warranty requests. By following the procedures instructed below, you are assured that you will receive the best level of customer service guaranteed.

- A) Please contact the local Dealer from whom you originally purchased within 30 days (unless otherwise noted by the Dealer) of discovery of the defect. Prepare to confirm that you are the original purchaser of the product and provide necessary product information, such as serial number(s)/UPC number(s) from the product in question.
- B) The Dealer will gather all the pertinent information required regarding your claim(s), inspect the product and thus contact a Z-Line Designs Customer Service Representative. (Please allow a reasonable amount of time for inspection, review, and response to Dealer.
- C) If the Z-Line Designs Dealer confirms that the product in review is eligible under the warranty conditions as stated above, the customer service representative or another representative of the Company will determine whether to provide replacement parts, or authorize other arrangements at the sole discretion of the vendor, Z-Line Designs. No assembly/labor is included in this warranty.

TO CONTACT CUSTOMER SERVICE:

Our knowledgeable Service Representatives are ready to assist you in the case this warranty applies to you. Please be prepared to explain the defect in detail, model/style number, date and location of purchase, your name, address, phone number and have your original sales receipt.

Please contact us Monday-Friday (except all major holidays) at:

Toll Free 1-888-736-2141 from 7:00 am – 3:30 pm (Pacific Standard Time) OR Email us: customerservice@z-linedesigns.com

OR

Contact your local dealer from whom you originally purchased the product in question.