

INSTALLATION INSTRUCTIONS

Ventilating Fan

FV-08VSL1

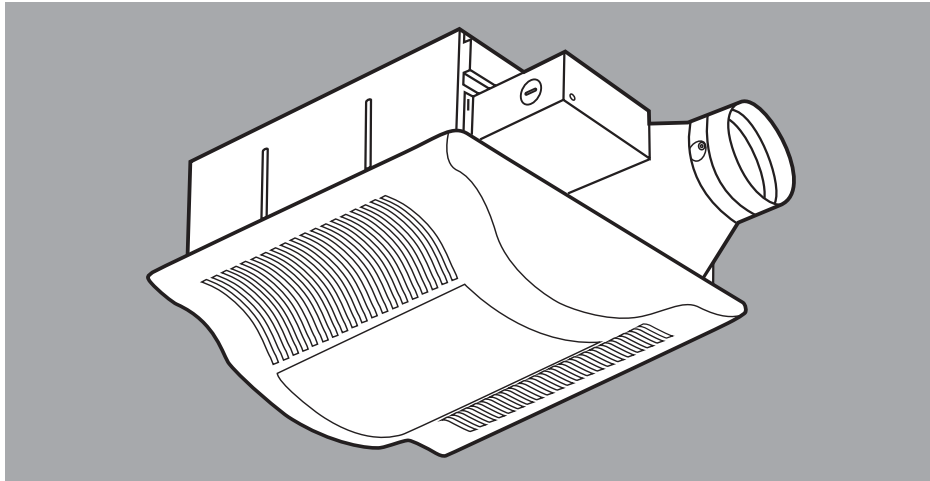

Panasonic®

READ AND SAVE THESE INSTRUCTIONS.





Please read these instructions carefully before attempting to install, operate or service the Panasonic Ventilating Fan. Failure to comply with instructions could result in personal injury and/or property damage. Please retain this booklet for future reference.





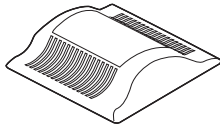
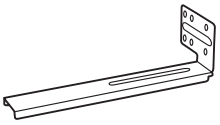
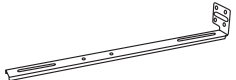
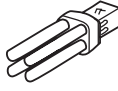

Table of Contents

Supplied Accessories	2
Description	2
Dimensions	3
Specifications	4
Unpacking	4
General Safety Information	4-5
Wiring Diagram	5
Installation I (Joist Mounting-I)	6-8
Installation I (Joist Mounting-II)	8-9
Installation III (I-Joist Mounting)	10
Installation IV (Between Joist Mounting)	10-11
Installation V (Wooden Header)	11-12
Installation VI (In Existing Construction)	12
Maintenance	13-14
Practical Guide to Installation	14
Product Service	14

SUPPLIED ACCESSORIES

FV-08VSL1

Part name	Appearance	Quantity
Grille		1
Suspension bracket I		1
Suspension bracket II		1
Suspension bracket III		1
Screw I (M4X8)		2
Screw II (M4X12)		2

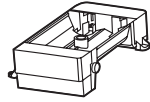
Part name	Appearance	Quantity
Screw III (M4X16)		2
Machine screw (M4X8)		1
Long screw (M4X30)		8
Thumb screw		1
18W Fluorescent lamp		2
4W Night lamp		1
Lighting unit		1

DESCRIPTION

The Panasonic ceiling mount ventilating fan uses a sirocco fan driven by a capacitor motor. The motor is designed to have an extended service life with reduced energy consumption. It also incorporates a thermal-cutoff for safety. The grille covering the main body is a spring-loaded, quick-release type. A damper for preventing counterflow is provided.

The light unit is an energy-saving, lighting device which uses two 18W fluorescent lamps and produces almost the same illumination as a standard 100W incandescent lamp.

DIMENSIONS

FV-08VSL1

Unit: inches(mm)

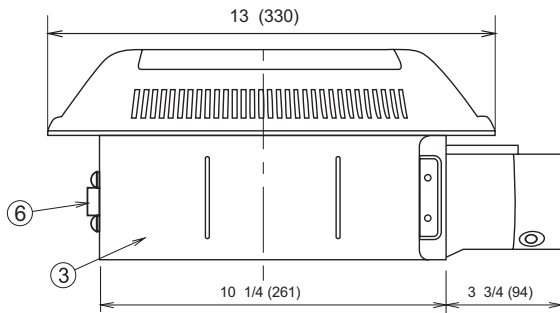
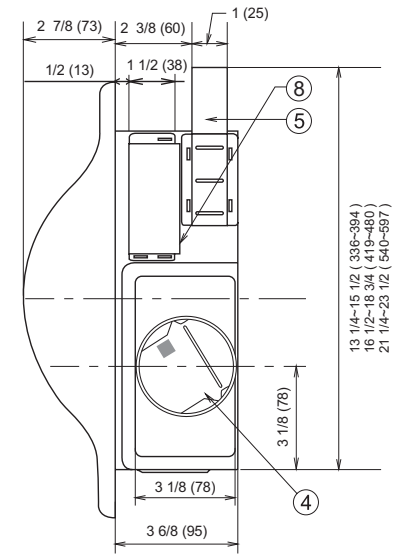
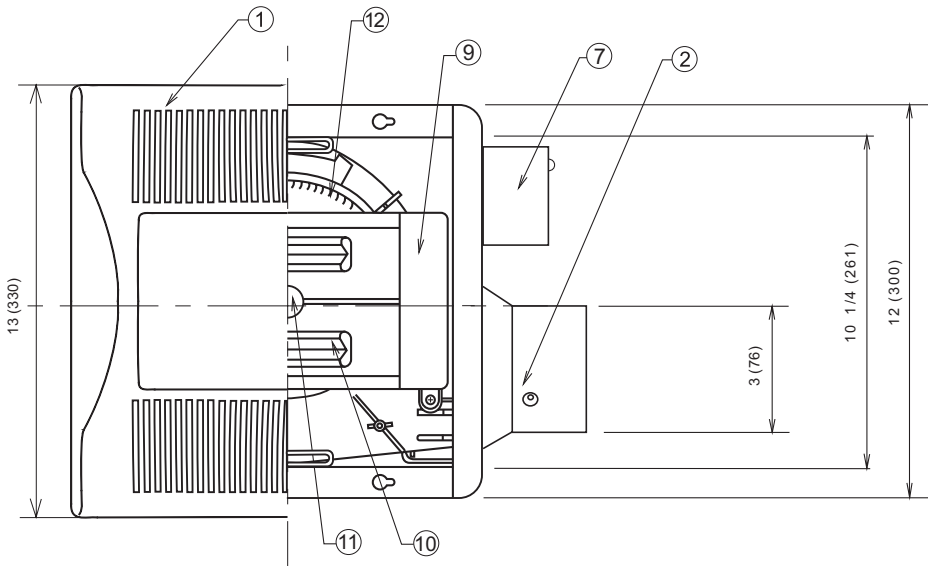

No.	Part name	No.	Part name
1	Grille	7	Junction box cover
2	Adaptor	8	Junction box
3	Fan body	9	Lighting unit
4	Damper	10	Fluorescent lamp
5	Suspension bracket	11	Night lamp
6	Bracket cover	12	Blade

(For 16 inches on center joists, only use suspension bracket I. For 19.2 inches on center joists, only use suspension bracket III. If more than 19.2 inches on center joists, use suspension bracket II & III.)

SPECIFICATIONS

Model	Air direction	V	Hz	Duct diameter (inches)	Noise (sone)	Power consumption (W)			Speed (rpm)	Air deliver at 0.1"WG (cfm)	Weight lb.(kg)
						Fan unit	Light unit				
							Fluorescent lamp	Night lamp			
FV-08VSL1	Exhaust	120	60	3	1.3	26	18 X 2	4	944	80	6.1 (13.4)

Specifications are based on HVI standard.

UNPACKING

Unpack and carefully remove unit from carton.
Refer to the Supplied Accessories list to verify that all parts are present.

GENERAL SAFETY INFORMATION

1. Do not install this ventilating fan where air temperature may exceed 40°C (104°F).
2. Make certain that the electric service supply voltage is 120V, 60 Hz.
3. Follow all local electrical and safety codes, as well as the National Electrical Code (NEC) and the Occupation Safety and Health Act (OSHA).
4. Always disconnect the power source before working on or near the fan, motor, light fixture or junction box.
5. Protect the power cord from sharp edges, oil, grease, hot surfaces, chemicals or other objects.
6. Do not kink the power cord.
7. Do not install the unit where ducts are configured as shown in Fig. A.
8. Provide suction parts with proper ventilation.
9. This unit is UL listed for use over a bathtub or shower when installed in a GFCI protected branch circuit.



Fig. A

GENERAL SAFETY INFORMATION CONTINUED

CAUTION:

1. For general ventilating use only. Do not use to exhaust hazardous or explosive materials and vapors.
2. Not for use in cooking area. (Fig .B)
3. This product must be properly grounded.

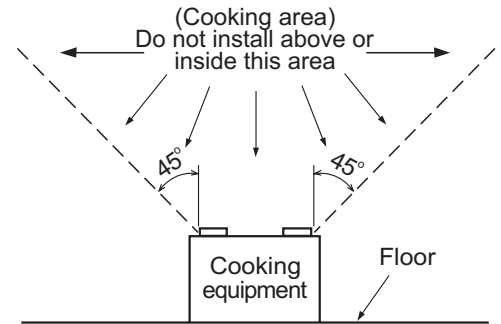

Fig. B

WARNING:

To reduce the risk of fire, electric shock or injury to persons, observe the following:

- A. Use this unit only in the manner intended by the manufacturer. If you have any questions, contact to the manufacturer.
- B. Installation work and electrical wiring must be done by qualified person(s) in accordance with all applicable codes and standards, including fire-rated construction.
- C. Sufficient air is needed for proper combustion and exhausting of gases through the flue (chimney) of fuel burning equipment to prevent backdrafting. Follow the heating equipment manufacturer's guideline and safety standards such as those published by the National Fire Protection Association (NFPA), and the American Society for Heating Refrigeration and Air Conditioning Engineers (ASHRAE) and the local code authorities.
- D. When cutting or drilling into wall or ceiling, do not damage electrical wiring and other hidden utilities.
- E. Ducted fans must always be vented to the outdoors.
- F. These models are UL listed for tub and shower enclosures.
- G. Solid state controls may cause harmonic distortion which can cause motor humming noise. To reduce the risk of fire or electric shock, do not use this unit with any solid-state control device.
- H. Before servicing or cleaning unit, switch power off at service panel and lock the service disconnecting means to prevent power from being switched on accidentally. When the service disconnecting means cannot be locked, securely fasten a prominent warning device, such as a tag, to the service panel.
- I. NEVER place a switch where it can be reached from a tub or shower.
- J. Not to be installed in a ceiling thermally insulated to a value greater than R40.

WIRING DIAGRAM

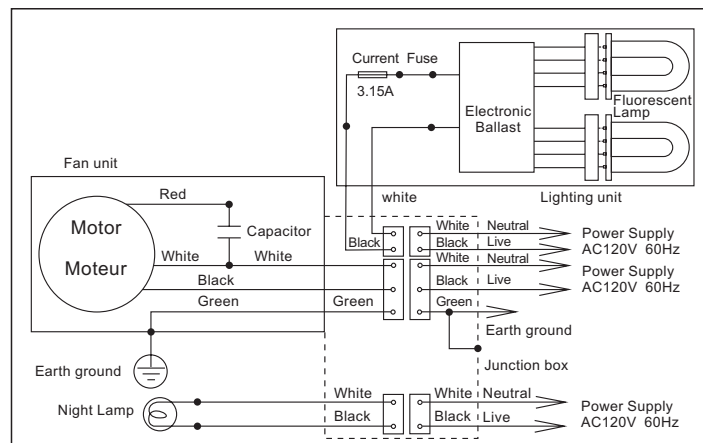

INSTALLATION I (JOIST MOUNTING-I)

1. Before installation, secure the fan body to adaptor by using thumb screw. (Fig.1)

IMPORTANT :

Remove the tape from damper and adaptor before installation. As shown below:

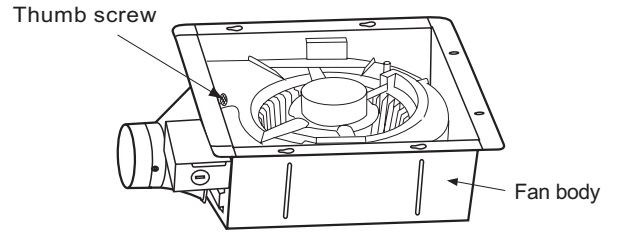
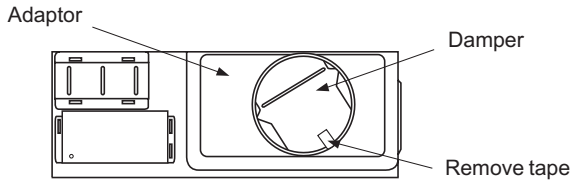

Fig.1

2. Insert the suspension bracket into the fan body and adaptor. (select the suspension bracket as shown below)

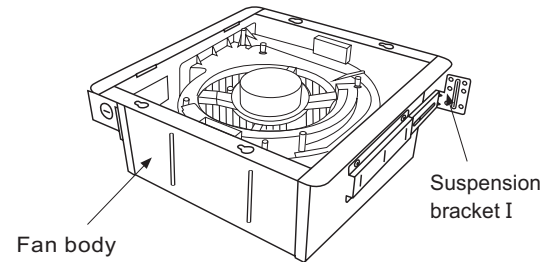
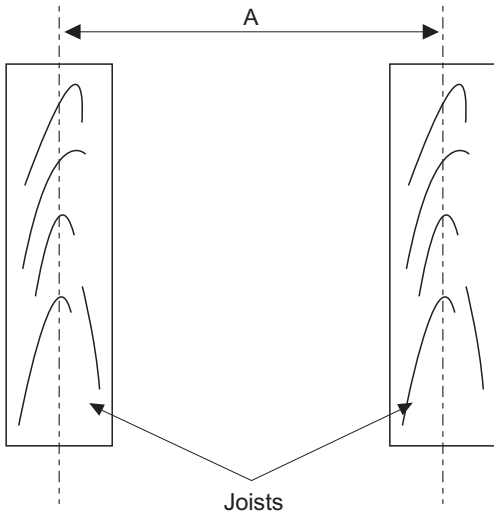

Fig.2-1

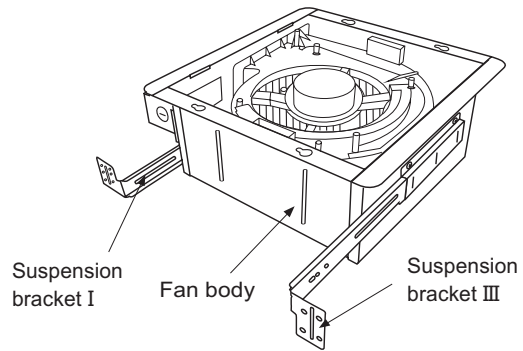

Fig.2-2

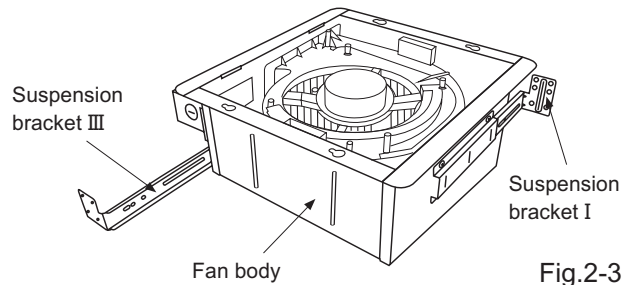

Fig.2-3

Spacing A on center Joists	Insert Suspension bracket
12 inches	Refer to Fig. 2-1
16 inches	Refer to Fig. 2-2
19.2 inches vertical joists	Refer to Fig. 2-3
24 inches	Refer to Fig. 2-4

If spacing A on center joists is 24 inches, connect suspension bracket II and III (C4 mark to C4 mark) as shown below :

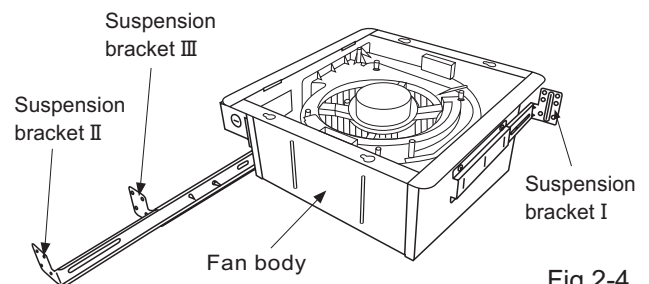
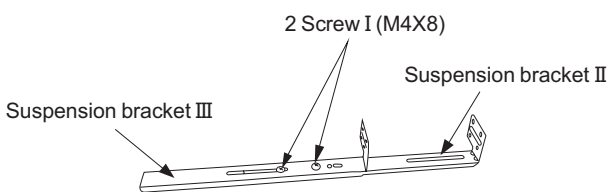
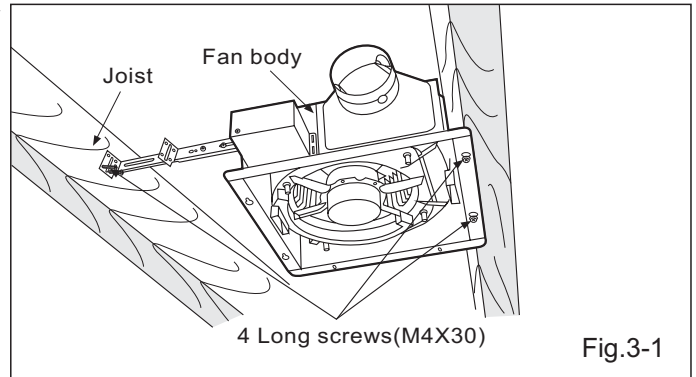

Fig.2-4

INSTALLATION I (JOIST MOUNTING-I) CONTINUED

3. Install the suspension bracket and the flange of fan body to joists by using long screws (M4X30) (If spacing A between joists is 10 1/4~12 inches, install the flange of fan body according to Fig.3-2, others according to Fig.3-1 install the product.)



A = 10 1/4~12 inches

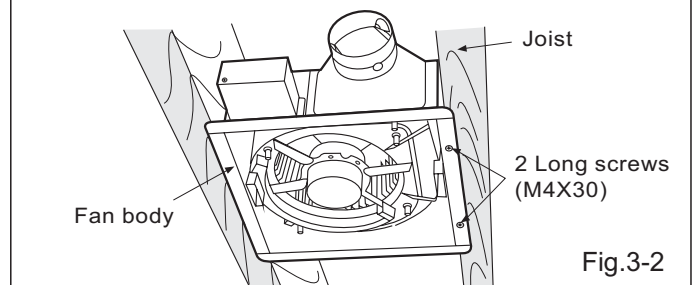

4. Install the suspension bracket to joists by using long screws (M4X30) and secure it to the fan body by using screw II (M4X12). (Fig.4)

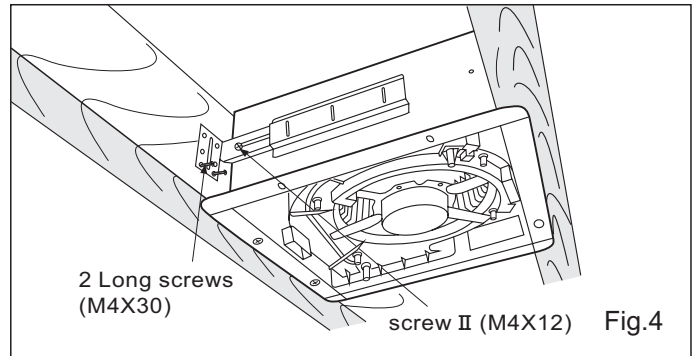

5. Remove junction box cover and secure conduit or stress relief to junction box knock-out hole. (Fig.5)

6. Refer to wiring diagram below.
Using wire nuts, connect house power wires to ventilating fan wires:
black to black; white to white; green to green;
Replace the junction box cover. (Fig.5)

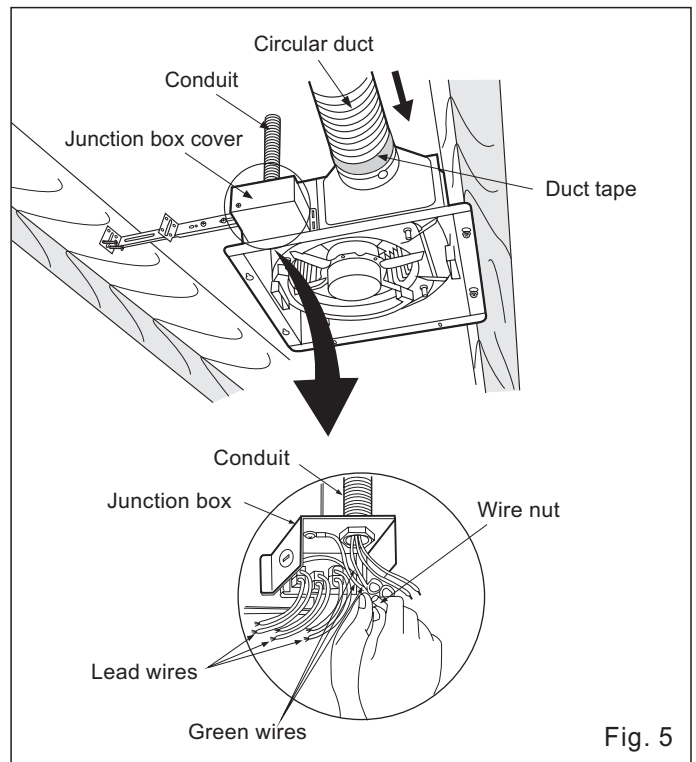

CAUTION:

Mount junction box cover carefully so that lead wires are not pinched.

7. Install a circular duct and secure it with duct tape or clamps.

INSTALLATION I (JOIST MOUNTING-I) CONTINUED

8. Finish ceiling work. Ceiling hole should be aligned with the edge of the flange. (Fig.6)

9. Insert the plug connector II and plug connector III into the receptacle II and receptacle III respectively, and secure the light unit to the fan unit with 2 screw III (M4X16) and 1 machine screw (M4X8). (Fig.6)

10. Insert the fluorescent lamps and screw the night lamp into the lighting unit. (Fig.6)

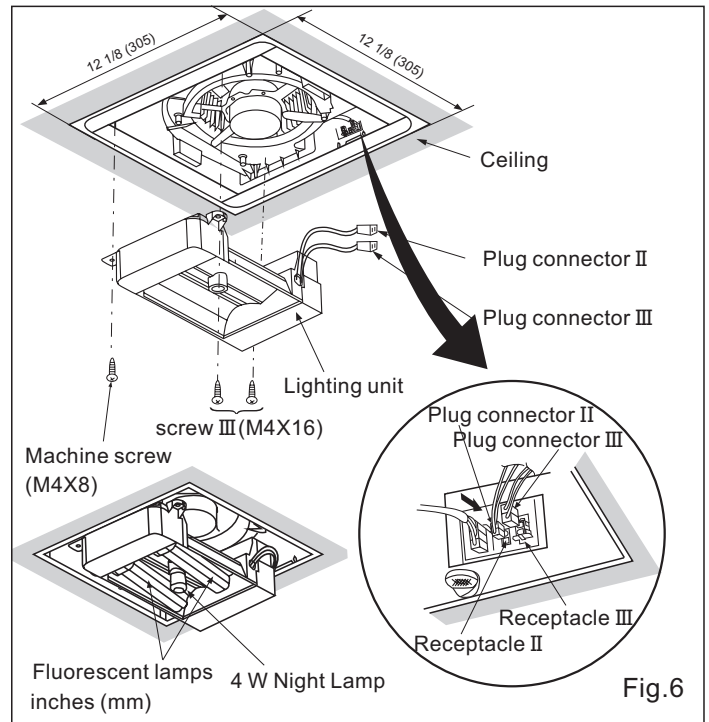

11. Insert mounting springs into slots as shown and mount grille to fan body. (Fig.7)

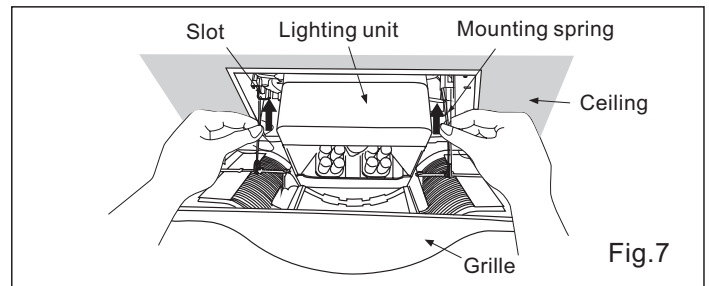

INSTALLATION II (JOIST MOUNTING-II)

1. Disconnect plug connector from receptacle and remove adaptor from fan body before starting installation.
2. Insert the suspension bracket into the adaptor and secure it to joists by using long screws(M4X30). (Fig.8)

CAUTION:

Ensure that distance B is no more than 1/2 inch (13 mm).

If spacing A between joists is 21 1/4 to 23 1/2 inches, connect suspension bracket II and III (C4 mark to C4 mark) according to page 6. Select the suspension bracket according to spacing A as shown below.

Spacing A between Joists inches (mm)	13 1/4~15 1/2 (336~394)	16 1/2~18 3/4 (419~480)	21 1/4~23 1/2 (540~597)
suspension bracket	suspension bracket I	suspension bracket III	suspension bracket II & III

3. Follow step 5 to 7 of the installation I (page 7) to complete the duct work and wiring.

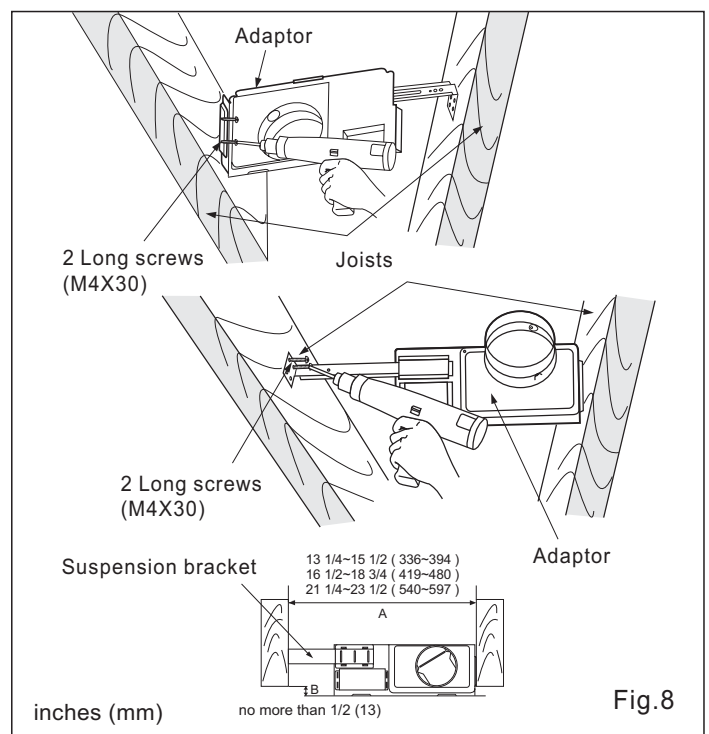

INSTALLATION II (JOIST MOUNTING-II) CONTINUED

4. Insert the suspension bracket into fan body (referring to step 2 of installation I, page 6).

5. Insert the fan body into joists. (Fig.9)

IMPORTANT:

Make sure that adaptor claws are properly inserted into body slots.

6. Secure the fan body to adaptor by using thumb screw and plug connector to receptacle. (Fig.10)

7. Secure the suspension bracket to joists by using long screws(M4X30) and secure it to fan body by using screw II(M4X12) in vertical direction. (Fig.11)

8. Follow step 8 to 11 of installation I (page 8) to complete the installation work.

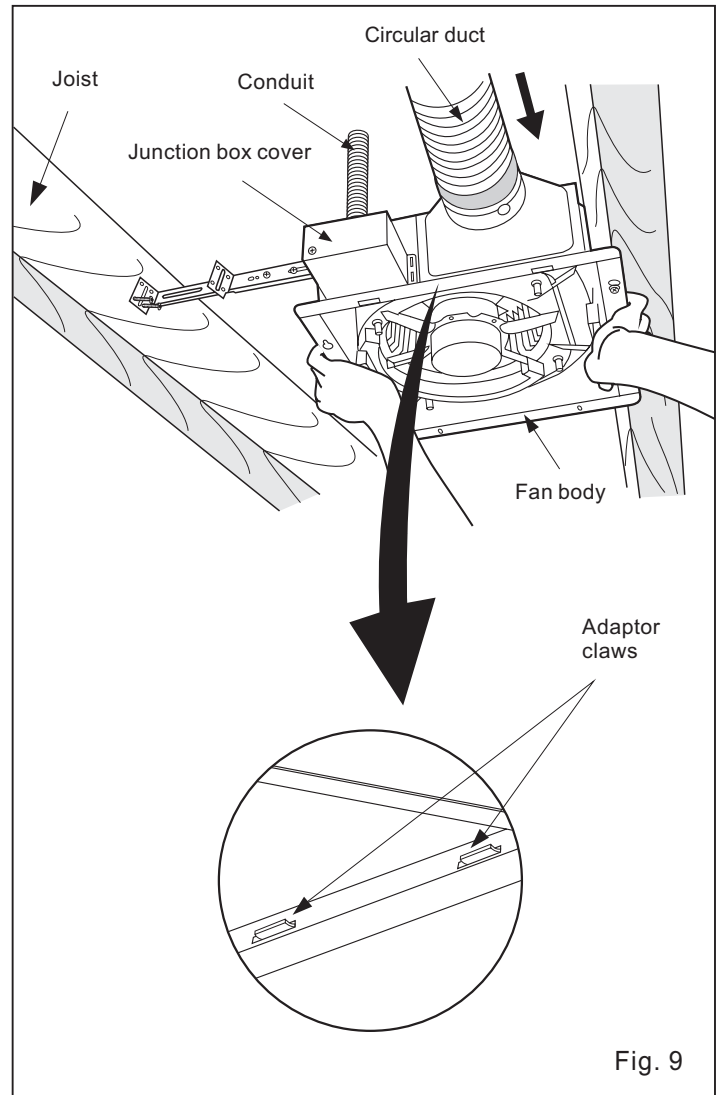

Fig. 9

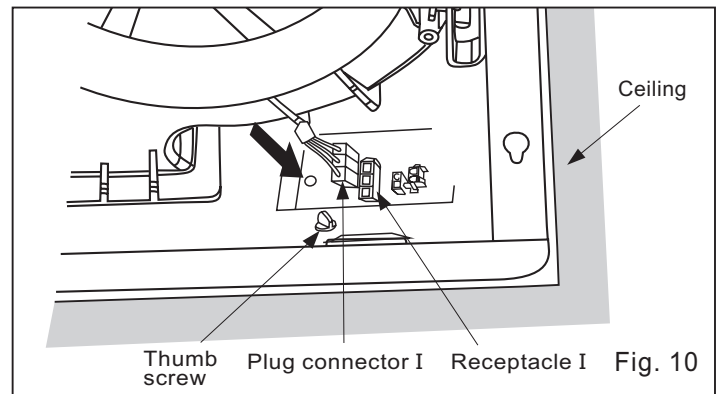

Fig. 10

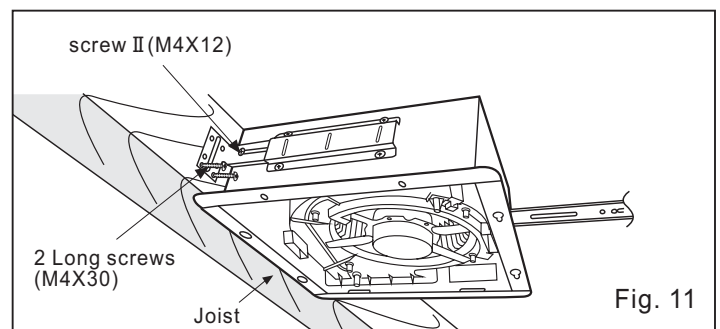

Fig. 11

When mounting body and blower separately

1. Loosen 4 screws (but do not remove them from blower). (Fig.12-1)

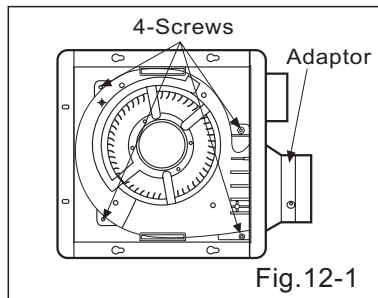

Fig.12-1

2. Remove blower section. (Fig.12-2)

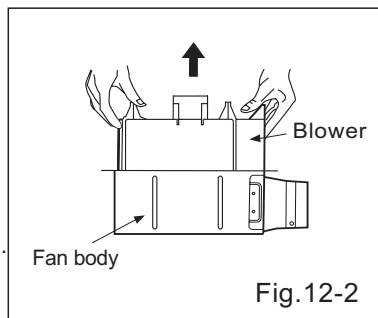

Fig.12-2

3. Remove adaptor from fan body and secure it to joists as in Fig.8 of page 8.

4. Insert fan body (without blower section) into joists. (Fig.9)

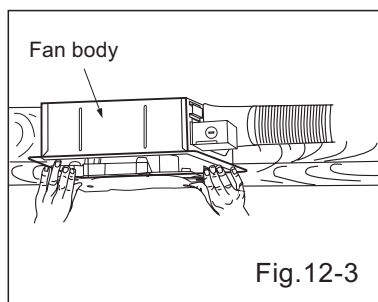

Fig.12-3

5. Secure the adaptor to fan body by using thumb screw. (Fig.10)

6. Secure the fan body to joists by using long screw(M4X30). (Fig.11)

7. Insert the blower into the fan body. (Fig.12-3)

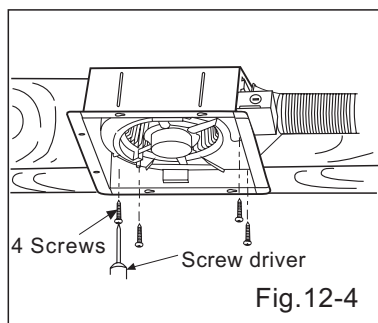
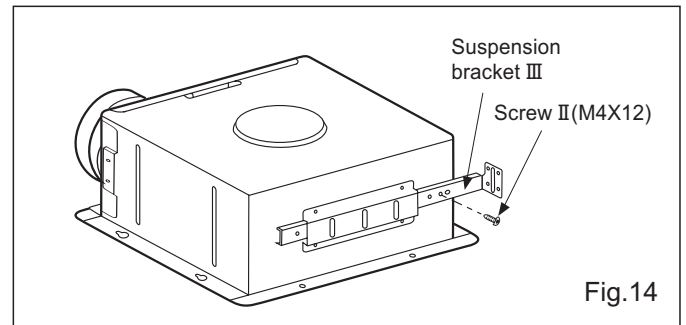
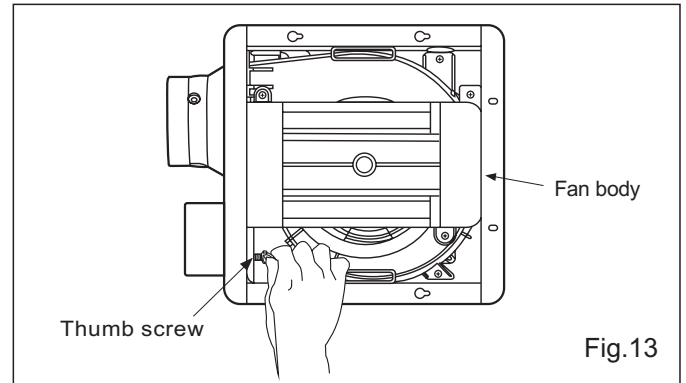
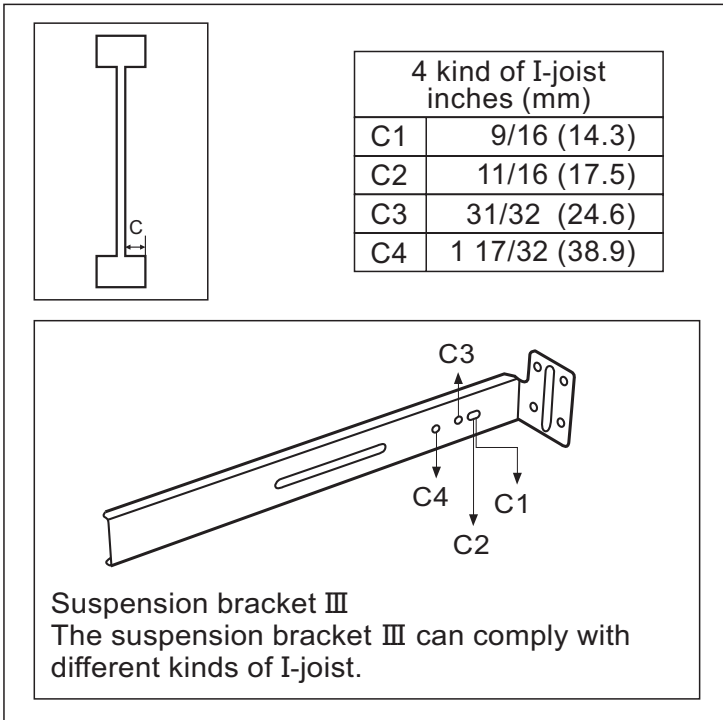

Fig.12-4

8. Secure the blower. (Fig.12-4) and plug connector to receptacle. (Fig.10)

INSTALLATION III (I - JOIST MOUNTING)



1. Before installation, secure the fan body to adaptor by using thumb screw (Fig.13). Secure the lighting unit to fan body (referring to Fig.6 of page 8).
2. Connect the suspension bracket III to fan body. (Fig.14) (Select the hole by checking I-joist size fix the screw to the frame hole.)
3. Connect the ventilating fan to the I-joist. (Fig.15)
4. Follow step 5 to 11 of installation I (page 7, page 8) to complete the installation work.

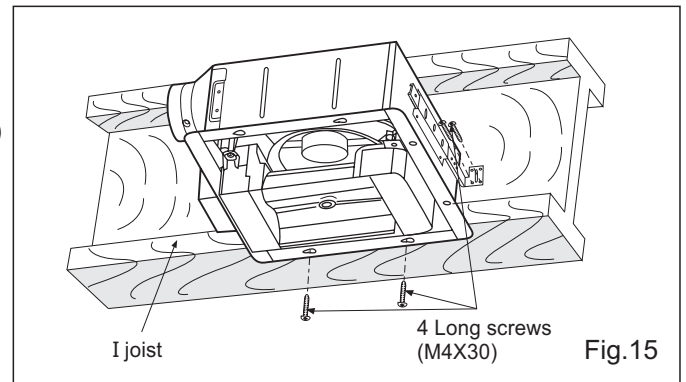

INSTALLATION IV (BETWEEN JOIST MOUNTING)

1. Before installation, secure the fan body to adaptor by using thumb screw (Fig.13). Secure the lighting unit to fan body (referring to Fig.6 of page 8).
2. Insert the suspension bracket into bracket cover of adaptor side and the back of the fan body. (Fig.16) (select the suspension bracket according to spacing A as shown below)

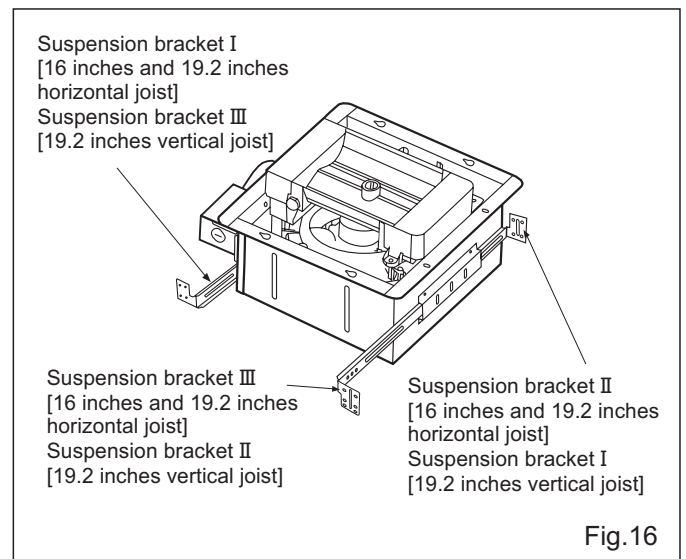
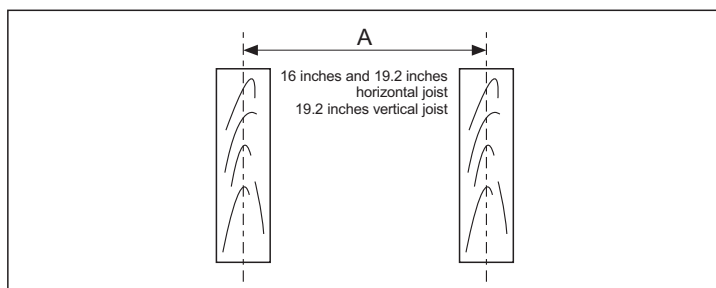

INSTALLATION IV (BETWEEN JOIST MOUNTING) CONTINUED

3. Insert the fan body between joists.
Make sure the fan body is level and square (perpendicular) with the joists. (Fig.17)

CAUTION:

Ensure that distance B is no more than 1/2 inch (13 mm).

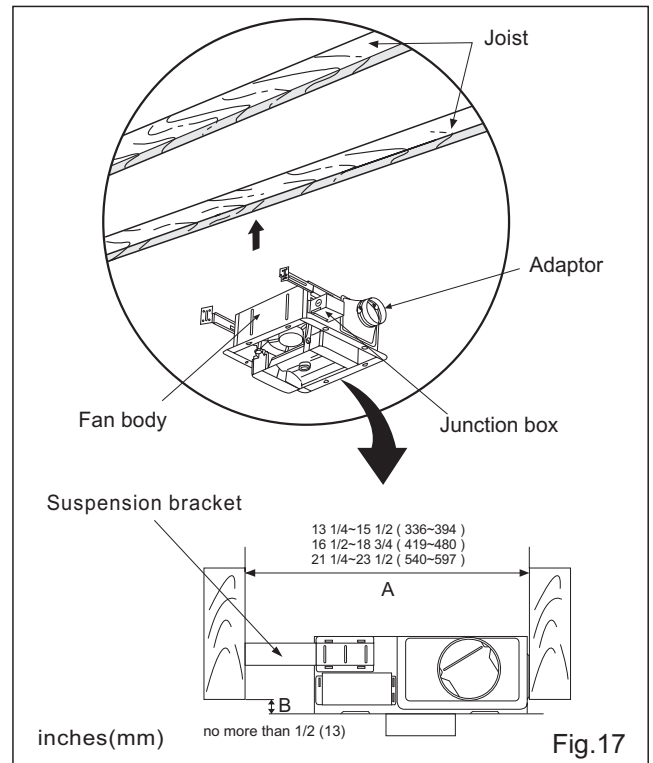

4. Secure the suspension bracket to joists by using long screws(M4X30). (Fig.18, Fig.19)

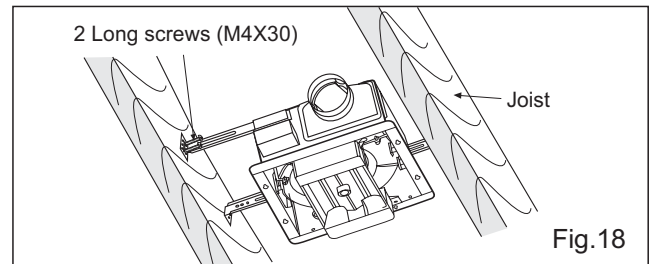

5. Secure the suspension bracket to fan body by using screw II (M4X12). (Fig.19)

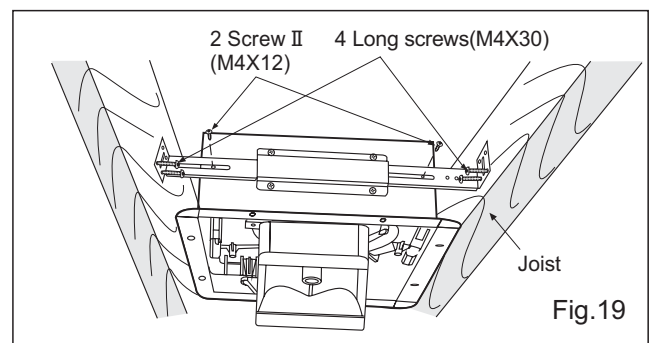

6. Follow step 5 to 11 of installation I (page 7, page 8) to complete the installation work.

INSTALLATION V (WOODEN HEADER)

1. Before installation, secure the fan body to adaptor by using thumb screw (Fig.13 of page 10). Secure the lighting unit to fan body (referring to Fig.6 of page 8).
2. Install header between joists by using nails or screws.
3. Install the fan body and secure it by using long screws(M4X30). (Fig.20, Fig.21)

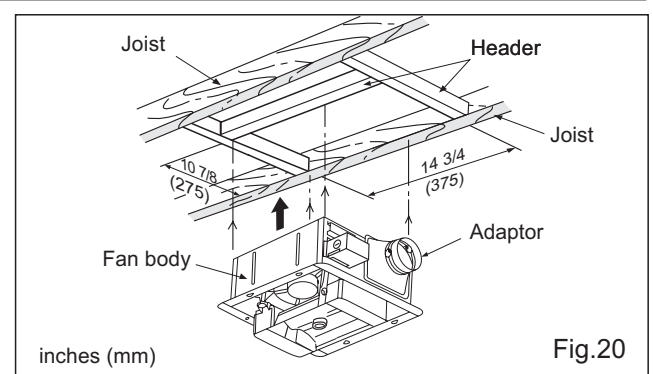

INSTALLATION V (WOODEN HEADER) CONTINUED

4. Follow step 5 to 11 of installation I (page 7, page 8) to complete the installation work.

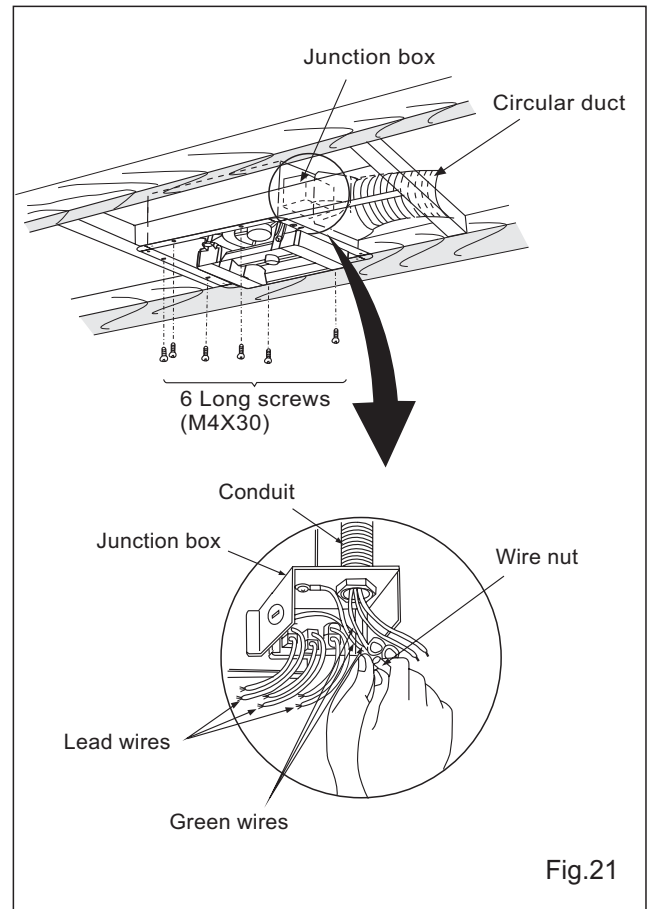

INSTALLATION VI (IN EXISTING CONSTRUCTION)

1. Installation in existing construction.
Installing the ventilating fan in an existing building requires an accessible area (attic or crawl space) above the planned installation location or existing ducting and wiring.
 - (1) To install the ventilating fan, follow the procedures described in Installation II. Take the following precautions before installation.

CAUTION:

Check area above planning installation location to be sure that:

1. Duct work can be done and that area is sufficient for proper ventilation.
2. Wiring can be run to planned location.
3. No wiring or other obstructions shall interfere with installation.

- (2) Inspect duct work and wiring before proceeding with installation.
 - (3) Plan suitable location for ventilating fan. (next to ceiling joist)
 - (4) Before installation, provide inspection and maintenance access at a location that will not interfere with installation work shown in installation II.
 - (5) First, remove ceiling section according to Fig.6 of page 8.
 - (6) Install ventilating fan.
2. Installation from accessible area above fan location.
 - (1) Inspect duct work and wiring before proceeding with installation.
 - (2) Remove ceiling section according to Fig.6 of page 8.
 - (3) Install ventilating fan.

MAINTENANCE I (CLEANING)

WARNING:

Disconnect power source before working on unit. Routine maintenance must be done every year.

CAUTION:

1. Never use petrol, benzene, thinner or any other such chemicals for cleaning the ventilating fan.
2. Do not allow water to enter motor.
3. Do not immerse resin parts in water over 60°C.

1. Remove grille. (Squeeze mounting spring and pull down carefully.) (Fig.22)
2. Wash and clean grille. (Use non-abrasive kitchen detergent, wipe dry with new cloth.) (Fig.23)
3. Remove dust and dirt from fan body using a vacuum cleaner. (Remove lamps if necessary.) (Fig.24)
4. Using a cloth dampened with kitchen detergent, remove any dirt from fan body. Wipe dry with new cloth. (Fig.25)
5. Replace lamps and grille.

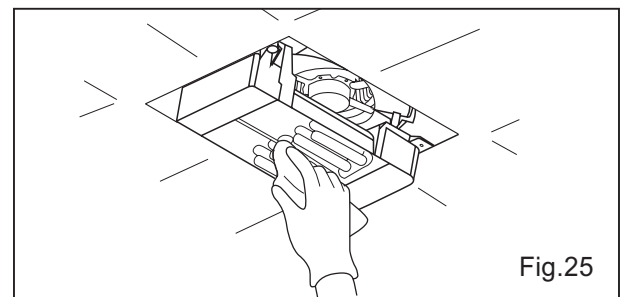
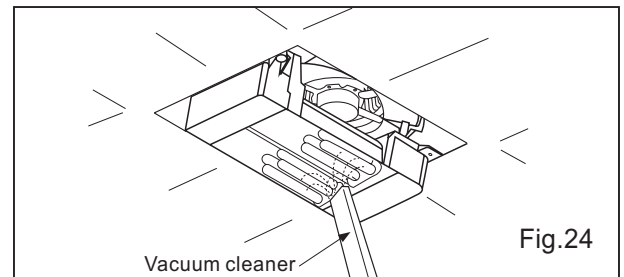
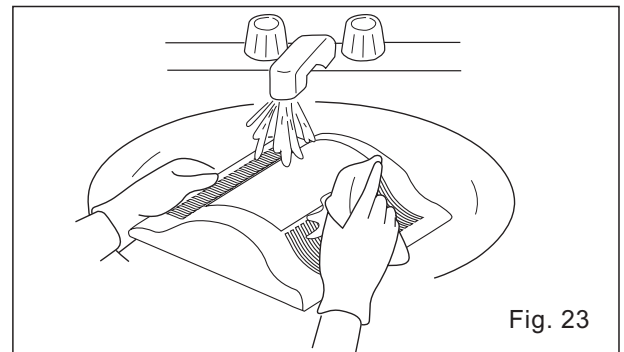
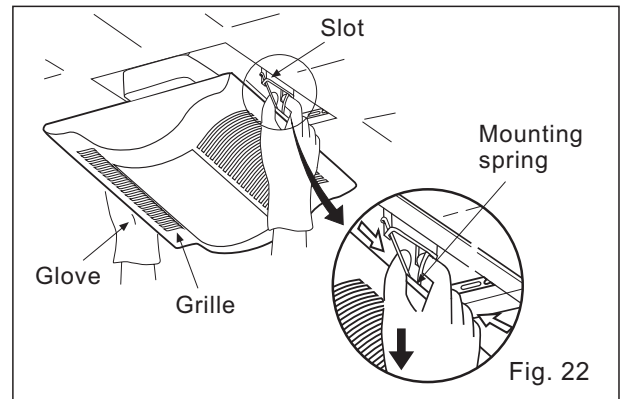

MAINTENANCE II (REPLACEMENT OF LAMP)

WARNING:

1. Disconnect power source before working on unit.
2. The lamp's glass is fragile. Please handle with care. To remove lamp, grasp at base and move back and force to loosen. Do not pull hard on the lamp or you may break the glass.
3. 4W night lamp has threaded base. Remove by turning counterclockwise.

MAINTENANCE II (REPLACEMENT OF LAMP) CONTINUED

1. Remove grille. (Squeeze mounting spring and pull down) (Fig.21 of page 13)

2. Disconnect connector II or connector III from lighting unit. (Fig.26)

3. Change the fluorescent lamps (Panasonic FDS 18E27/4, 18W or FDS18E35/4, 18W or FDS18E42/4, 18W) or the 4W night lamp, connect the connector II or connector III and replace the grille. (Fig.27)

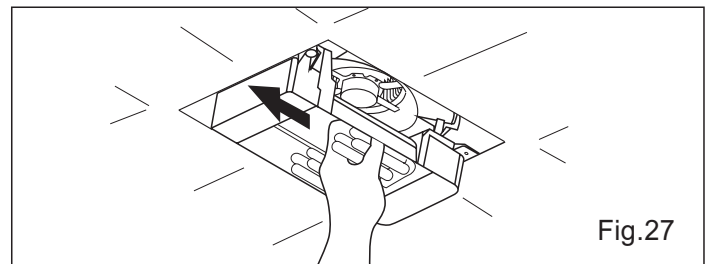
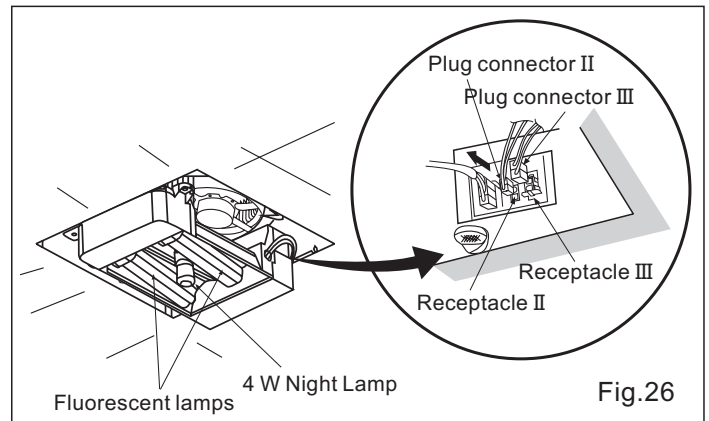

PRACTICAL GUIDE TO INSTALLATION

Properly insulate the area around the fan to minimize building heat loss and gain. (Fig.28)

Loose fill or batt insulation can be placed directly over the fan housing in the attic. Panasonic fans and fan/light combination units do not create excessive heat that is a common problem with recessed light fixtures or some competitors' fan/light combinations. Our efficient, cool-running motors and our fluorescent lamps do not create enough ambient heat to be subjected to these limitations.

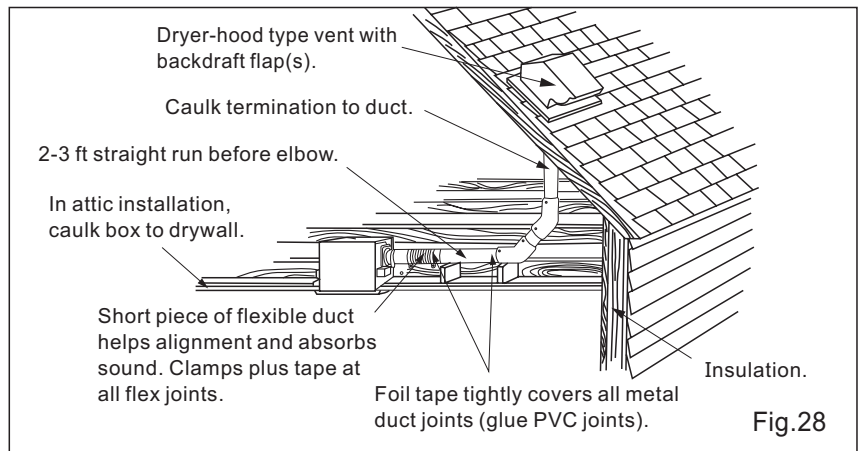

PRODUCT SERVICE

Warning Concerning Removal of Covers.

The unit should be serviced by qualified technicians only. No service information is provided for customers. Your product is designed and manufactured to ensure a minimum of maintenance. However, should your unit ever require service, a nationwide system of factory service centers and AUTHORIZED INDEPENDENT SERVICE CENTERS is maintained to support your product's warranty. (In the U.S.A., call 1-866-292-7292 to Customer call Center.)

PANASONIC CONSUMER ELECTRONICS COMPANY

One Panasonic Way, 1H-3 Secaucus, NJ, 07094

PANASONIC CANADA INC.

5770 Ambler Drive, Mississauga, ON L4W 2T3