

P4500 Series Pedestal Mounts

Verify sufficient clearance from walls and other furniture to permit mounting plate and television to swivel when installed. Test remote operation for potential obstructions.

1. Use pedestal base as template to mark location for drilling at off-center hole in base.

Concrete floor: Drill 1/2" x 2-1/2" deep hole into floor. Insert provided anchor bolt into hole and turn nut to secure anchor bolt. Remove nut from anchor bolt. Place pedestal base over protruding thread of anchor bolt, slipping bolt through the off center hole in pedestal base. Replace nut on anchor bolt and retighten.

Wood floor: Drill pilot hole for provided lag bolt. Place two washers on lag bolt and insert bolt through off-center hole in pedestal base. Screw lag bolt into floor.

2. Screw provided 1/2" diameter rod into threaded hole in pedestal base.

3. Place 2" diameter tube over the 1/2" threaded rod and into pedestal base. Place a piece of wood over top of tubing and tap firmly with a hammer to force bottom of tube into pedestal base.

4. Place two provided 2-1/8" washers over threaded rod and into tube, resting them on recessed ring in top of tube. Verify that washers are evenly seated and that a minimum of 7/8" of threaded rod is protruding through washers.

5. Place lower plate on pedestal tube, slipping threaded rod through hole in center of plate. Rotate plate until nodules on swivel plate slip into notches in top of tube. Place 1/2-13 nylon lock nut on threaded rod and tighten.

6. Invert monitor. Position inverted upper plate on bottom of monitor with lock slot facing front of monitor. Attach monitor to upper plate with fasteners appropriate to the underside of the monitor.

7. Turn monitor right side up. Place upper plate on lower plate, guiding rear of upper plate beneath lip at back of lower plate. Slip upper plate into lower plate and pull forward until front of upper plate meets front of lower plate.

8. Place key in lock and insert lock into lock retainer. Turn key clockwise until lock is completely screwed in, then turn back (counterclockwise) until key is vertical. Remove key.

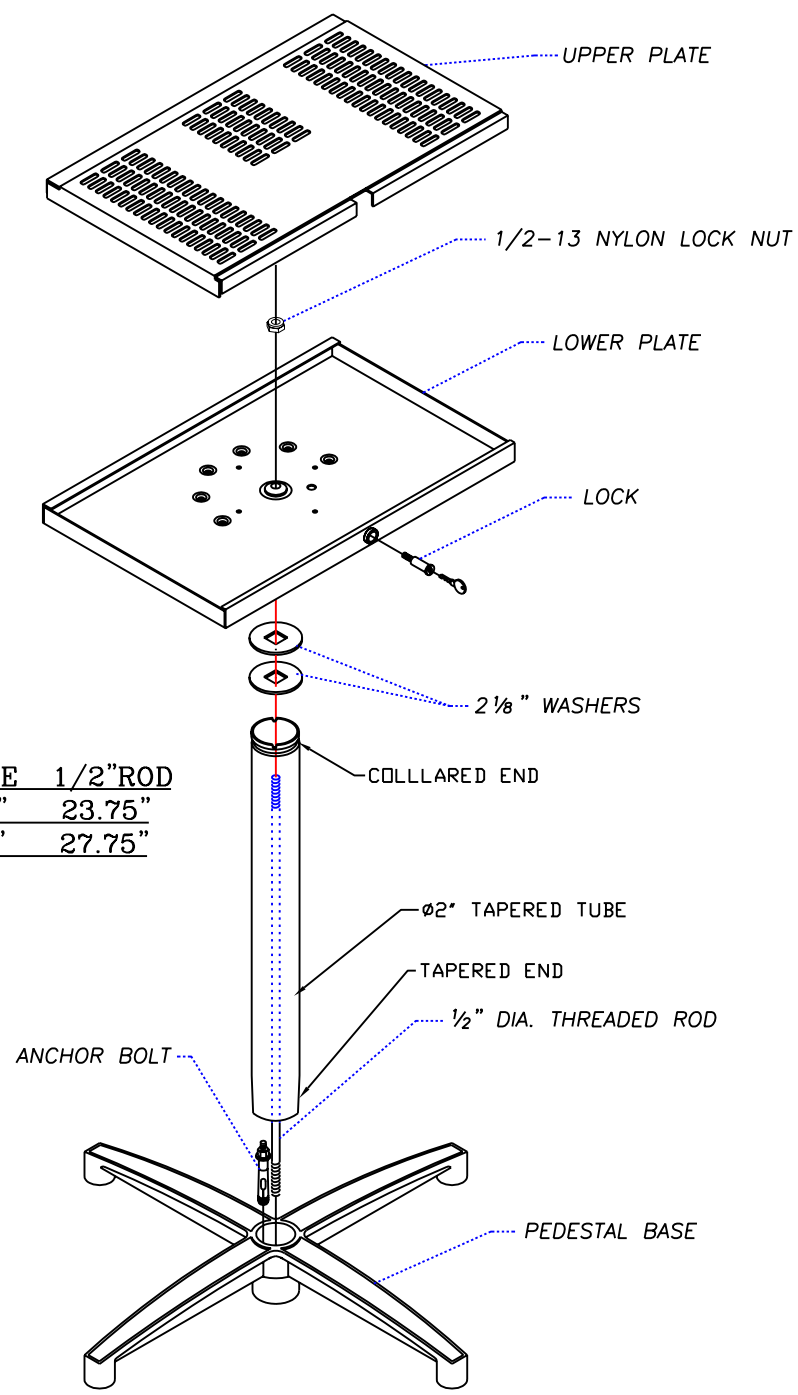

PART #	TUBE	1/2" ROD
P4500	22"	23.75"
P450028	26"	27.75"