

FSWT Flat Screen 0° - 15° Tilt Wall Mount

Direct Monitor Attachment

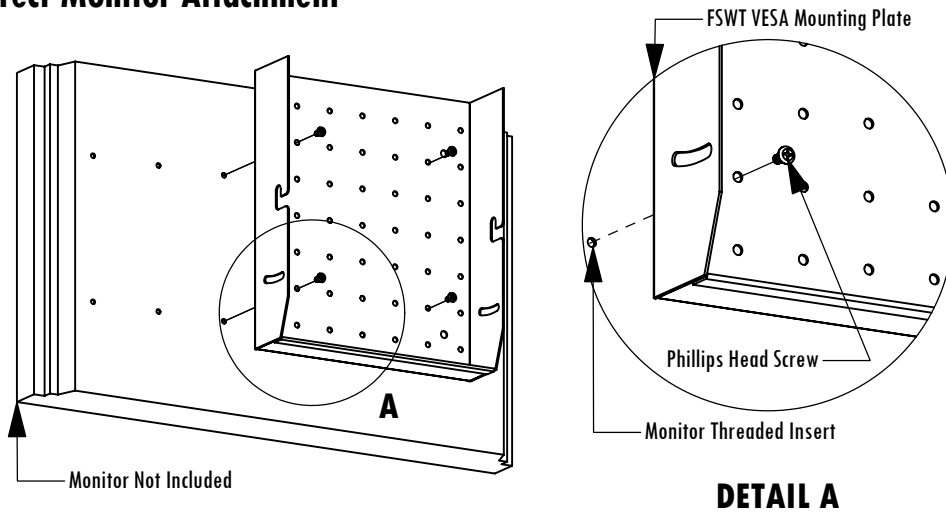

Determine which type of monitor attaching hardware is required for the monitor as specified by the monitor manufacturer. Various sizes of monitor attaching screws are provided for convenience (See the Hardware List below). If mounting the monitor directly to the FSWT VESA Mounting Plate, follow the Direct Monitor Attachment instructions. If mounting the monitor using an Adaptor Plate, follow the Monitor Attachment with Adaptor Plate instructions.

Direct Monitor Attachment

Use fasteners as specified by the monitor manufacturer to attach the monitor directly to the FSWT VESA Mounting Plate. (DETAIL A)

Monitor Attachment with Adaptor Plate

Secure the Adaptor Plate to the FSWT VESA Mounting Plate with the provided hex bolts, nuts, and washers. (DETAIL B) Refer to the specific Adaptor Plate instructions to attach the adaptor plate to the monitor.

Monitor Attachment with Adaptor Plate

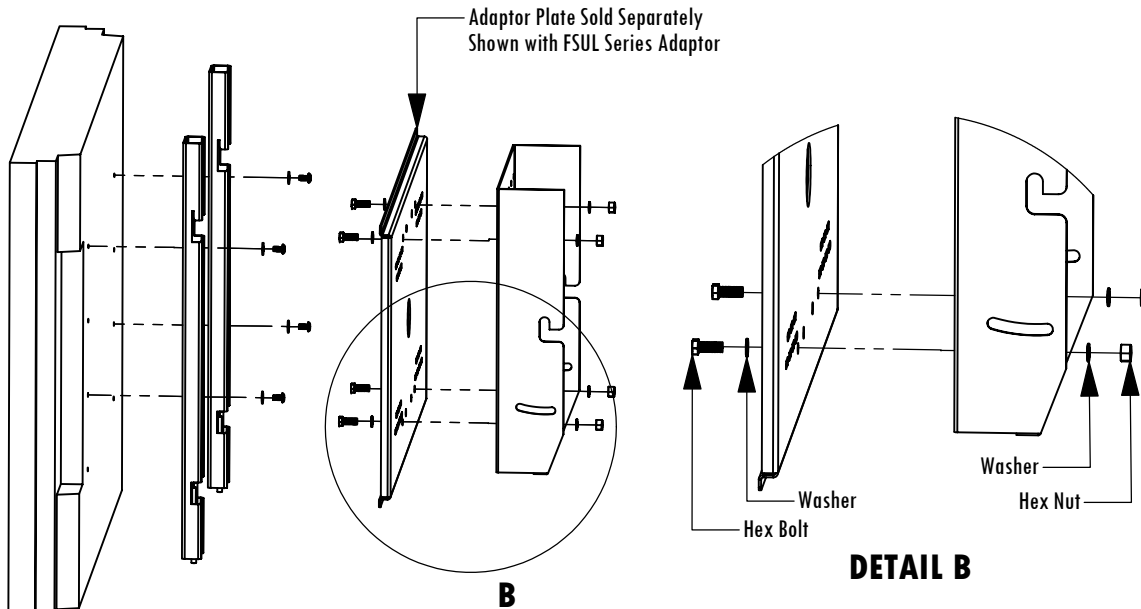

Hardware List

#14 x 2-1/2" HWH Lag Screws	6		
1/4" x 1-1/4" Fender Washers	3		
3/8" Flat Washers, Black	4		
3/8" Nylock Nuts, Black	4		
3/8-16 x 3/4" Hex Bolt, Black	2		
1/2-13 Nylock Nuts, Black	2		
5/16-18 x 3/4" Hex Bolts, Black	4		
5/16" Flat Washers, Black	8		
5/16-18 Hex Nuts, Black	4		
4mm x 25mm Set Screws ...	4	4mm Hex Nuts ...	8
5mm x 30mm Set Screws ...	4	5mm Hex Nuts ...	8
6mm x 30mm Set Screws ...	4	6mm Hex Nuts ...	8
4mm x 12mm Phillips Screws ...	4	5mm Flat Washers ...	24
5mm x 12mm Phillips Screws ...	4	1/4" Flat Washers ...	12
6mm x 12mm Phillips Screws ...	4		

FSWT Flat Screen 0° - 15° Tilt Wall Mount

Single Stud Install

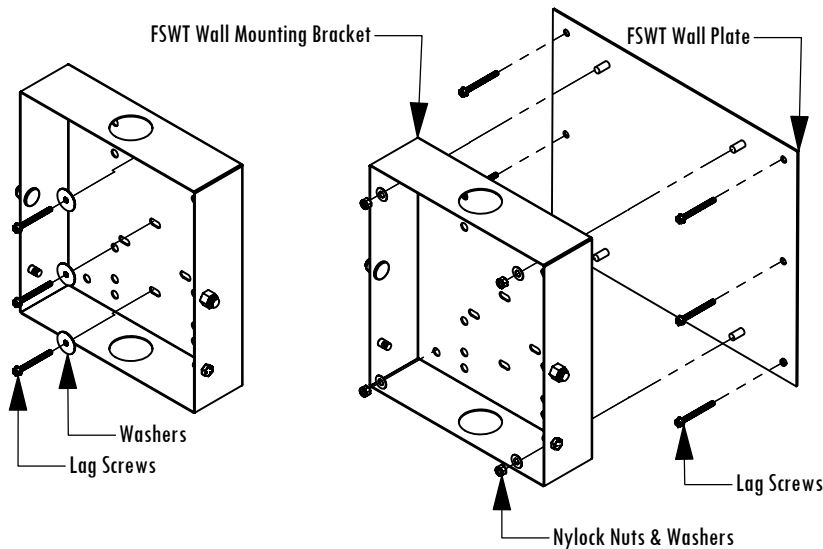

Double Stud Install

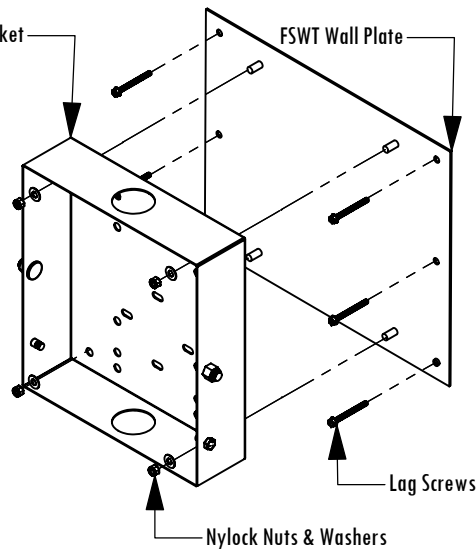

Wood Lag Screws are provided for wood stud installations. For concrete or metal studs, use the WMAAB6, concrete anchor bolt kit, or WMATB6, toggler bolt kit, and follow the instructions specific to these fasteners.

For monitors over 50 lbs., use the Double Stud Installation instructions. For monitor under 50 lbs., use either the Single or Double Stud Installation instructions.

Single Stud Installation

1. Find a wood stud in the wall. Determine the best possible viewing location on the wall.
2. Use the FSWT Wall Mounting Bracket as a template to mark the locations for three wood screw pilot holes.
3. Drill the pilot holes using a 1/8" drill bit, 2-3/4" deep.
4. Attach the FSWT Wall Mounting Bracket to the wall using the three provided Lag Screws.

Double Stud Installation

1. Find two wood studs in the wall on 16" centers. Determine the best possible viewing location on the wall.
2. Use the FSWT Wall Plate as a template to mark the locations for six wood screw pilot holes.
3. Drill the pilot holes using a 1/8" drill bit, 2-3/4" deep.
4. Attach the FSWT Wall plate to the wall using the six provided Lag Screws.
5. Attach the FSWT Wall Mounting Bracket to the Wall Plate with the provided Nylock Nuts and Washers.

Attaching Monitor to Wall Mounting Bracket

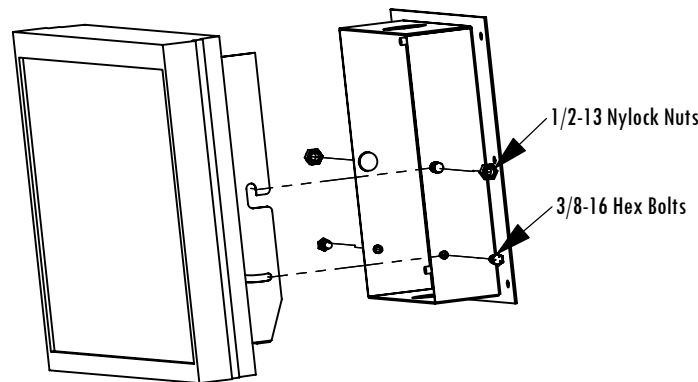

Attaching Monitor to Wall Mounting Bracket

1. Raise the monitor with attached brackets to the FSWT Wall Mounting Bracket and slip the slots of the FSWT VESA Mounting Plate over the studs on the FSWT Wall Mounting Bracket. Check to make sure the FSWT VESA Mounting Plate Slots are fully engaged and seated.
2. Adjust Tilt to the desired viewing angle.
3. Secure with the provided Nylock Nuts and Hex Bolts.