

## *Installation Instructions / Warranty*

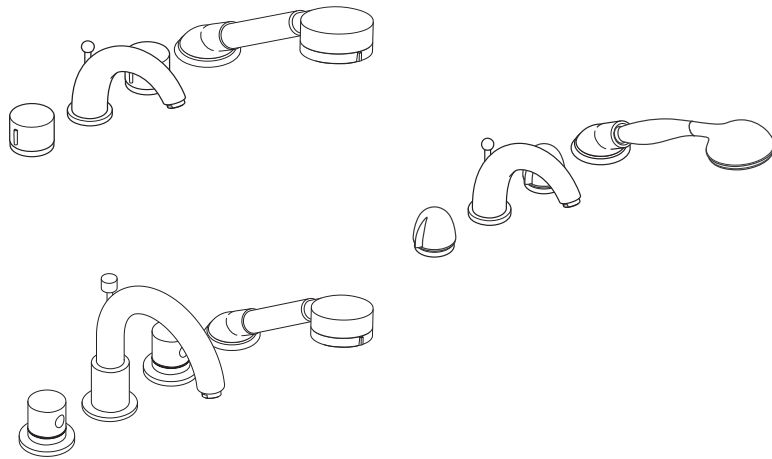

### *4-Hole Roman Tub Trim*

Steel 35447801  
Allegroh 36447XX1  
Uno 38447XX1

**AXOR**<sup>®</sup>  
hansgrohe

90863004-01 05/2005

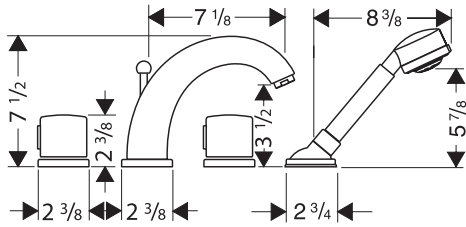

35447801

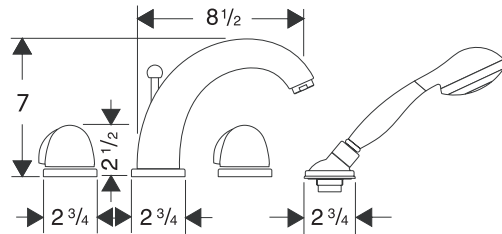

36447XX1

### Installation Considerations

- This trim kit must be used with rough-in 13444-18. The handshower must be used.
- Backflow protection is provided by a check valve in the handshower connection hose. Additionally, the diverter will automatically spring back to the "spout" position if a backflow condition exists.

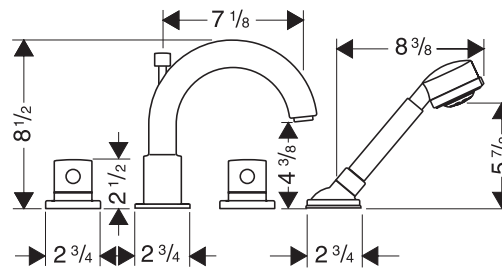

38447XX1

**Roman tub rough 13444181 is listed by UL.**

### Product Specifications

Recommended operating pressure	45 - 80 psi
Recommended hot water temperature	120° - 140° F*
Flow rate - handshower	2.5 gpm
Flow rate - valves	approx. 6 gpm each
Hole sizes - see template included with rough-in for placement	
Valves	1 3/16"
Spout	1 3/8"
Spout Adapter Pin	3/16"
Handshower	2"
Maximum mounting surface thickness	2"
90° Ceramic cartridge operation.	

\* Some governing agencies require that the water heater be set to 120o F or less. Please know and follow all applicable local codes when setting the temperature on the water heater.

## Replacement Parts

### 35447801

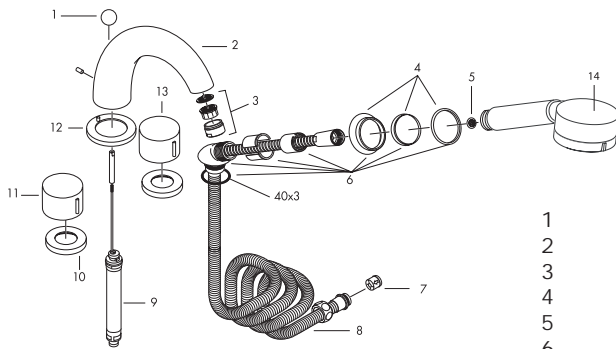

1	pull knob	94102XXX
2	spout	96255XXX
3	aerator	13485XXX
4	escutcheon	94052XXX
5	screen washer	94246000 (25)
6	shower holder	92380XXX
7	check valve	94074000
8	inner hose	94148000
9	diverter	96256000
10	escutcheon	94116XXX
11	hot handle	35292800
12	spout escutcheon	95023XXX
13	cold handle	35291800
14	handshower	35852801

### 36447XX1

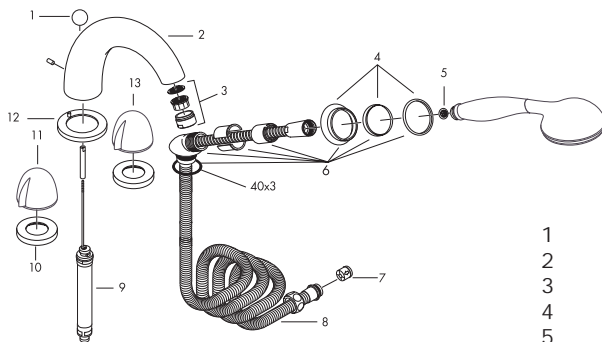

1	pull knob	94102XXX
2	spout	96255XXX
3	aerator	13485XXX
4	escutcheon	94052XXX
5	screen washer	94246000 (25)
6	shower holder	92380XXX
7	check valve	94074000
8	inner hose	94148000
9	diverter	96256000
10	escutcheon	94116XXX
11	hot handle	36292800
12	spout escutcheon	95023XXX
13	cold handle	36291800
14	handshower	36850XXX

xxx = color

000 = chrome

090 = chrome/gold

880 = satin chrome

## 38447XX1

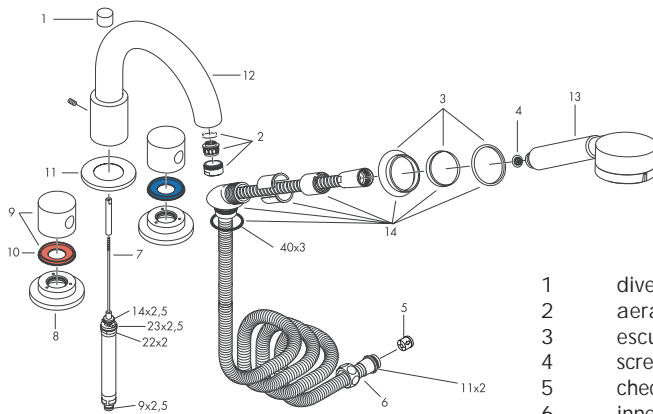

1	diverter knob	96475XXX
2	aerator	13956000
3	escutcheon	94052XXX
4	screen washer	94246000 (25)
5	check valve	94074000
6	inner hose	94148000
7	diverter	96506000
8	escutcheon	96474XXX
9	handle	38092XXX
10	color ring hot/cold	96422000
11	escutcheon	96782XXX
12	spout	96471XXX
13	handshower	38850XXX
14	handshower holder	92380XXX

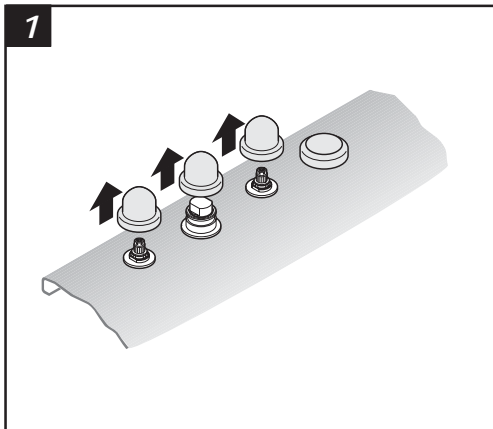

### Installation

- Remove the plastic plaster shields from the valves and the spout tee. Make sure that the white plastic snap connectors are screwed firmly to the valve stems.

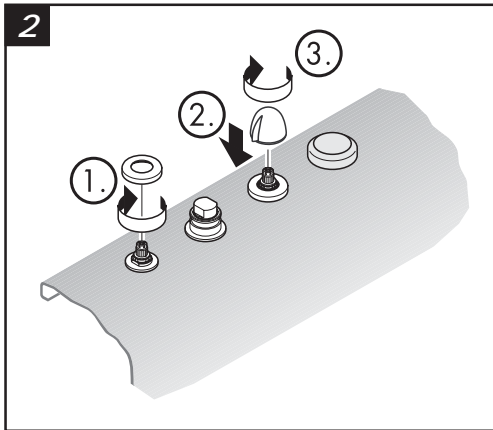

- Install the escutcheons (1). Position the handles over the valves (2). Press down firmly over the snap connectors (3).

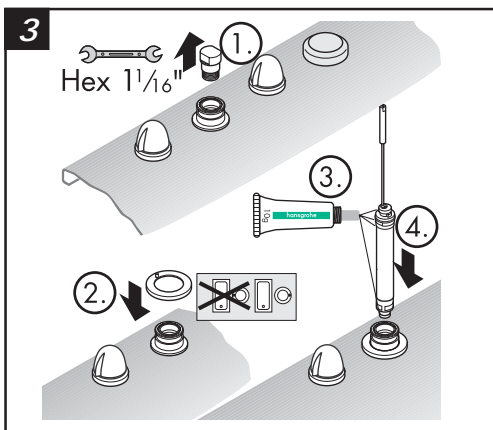

- Remove the brass plug from the spout tee with a 27 mm wrench (1). Install the spout escutcheon with the positioning pin facing away from the tub (2).
- Lightly lubricate the o-rings on the diverter with the enclosed lubricant (3). Firmly push the diverter straight down into the spout tee (4).

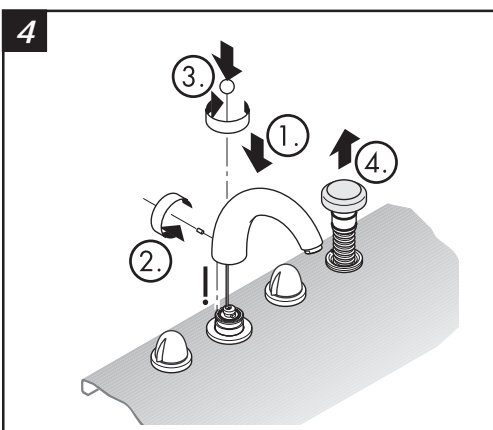

- Place the spout over the diverter assembly (1). Tighten the set screw, using the enclosed 3 mm allen wrench (2). Thread on the diverter knob (3).
- Pull the outer Secuflex™ hose through the handshower mount (4).

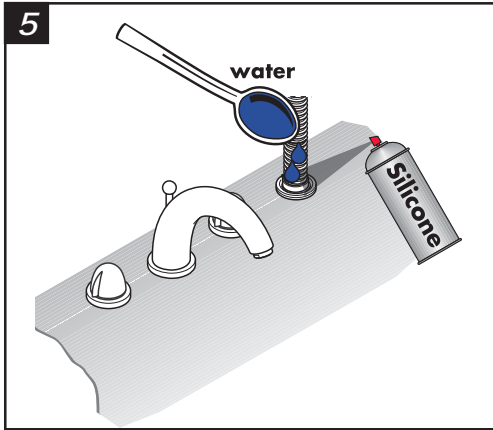

- Lubricate the handshower mount and outer Secuflex™ hose with spray silicon lubricant or with a tablespoon or so of water.

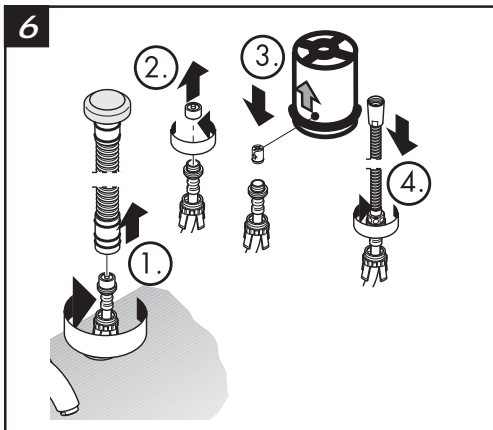

- Pull the outer Secuflex™ hose completely from the handshower mount. Unscrew the outer Secuflex™ hose (1) from the handshower connector hose (2). Do not allow the handshower connector hose to fall back through the hole!
- Remove the brass plug (3) from the handshower connector hose (2).
- Install the check valve(4) to the handshower connector hose.

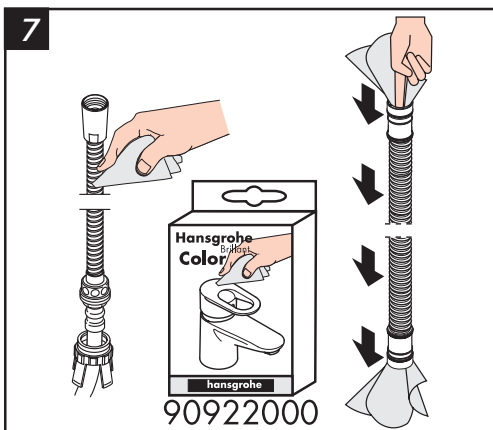

- Use the enclosed cleaning towelette to thoroughly clean the outer Secuflex™ hose.

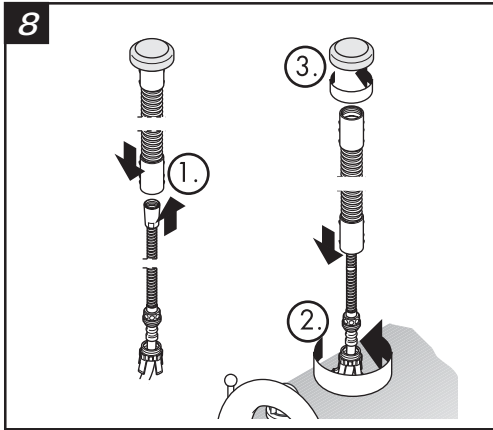

- Feed the inner Secuflex™ hose through the outer Secuflex™ hose (1)
- Attach the inner Secuflex™ hose to the handshower connector hose (2).
- Remove the plaster guard from the outer Secuflex™ hose (3).

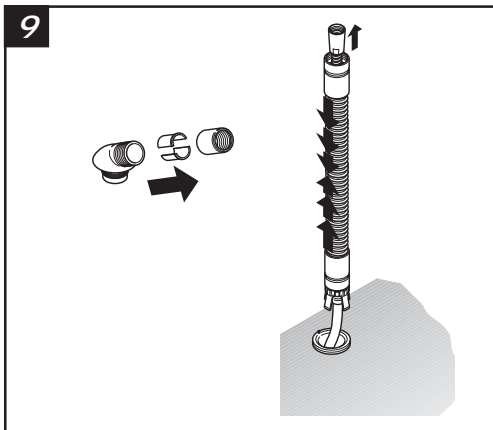

- Remove the end cap and the liner from the handshower holder.
- Compress the outer hose until you can grasp the end of the inner hose

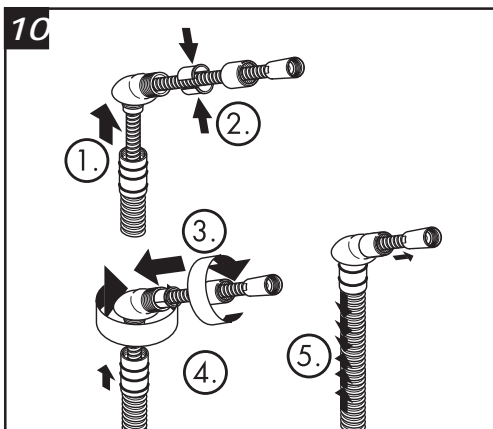

- Feed the inner hose through the handshower holder (1), liner (2), and end cap (3).
- Screw the end cap (4) over the end of the handshower holder.
- Continue pulling „out“ on the inner hose (5).

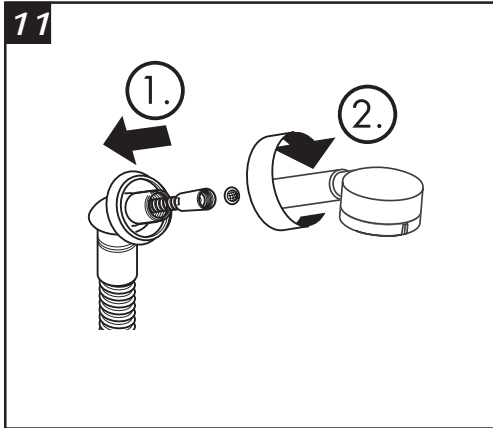

- Place the handshower holder retainer ring (1) over the hose and the handshower holder.
- Install the screen washer and the handshower on the hose (2).

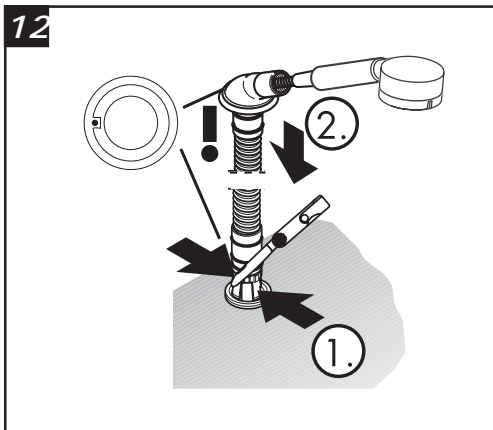

- Use a knife to cut the o-rings at the end of the outer hose (1).
- Feed the hoses back through the handshower mount (2).
- Place the handshower holder onto the handshower mount so that the pin on the mount engages the corresponding hole on the handshower holder.

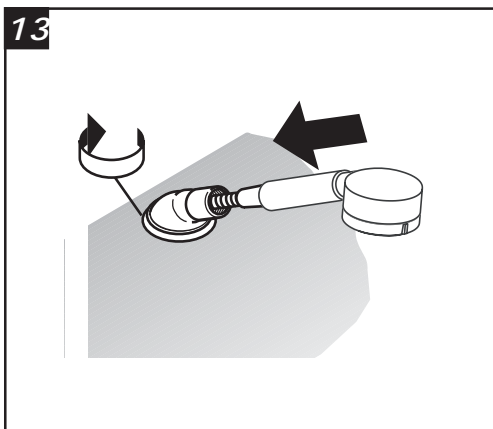

- Secure the handshower holder to the handshower mount with the retainer ring.

---

## User Instructions

- Turn the right handle for cold water, the left handle for hot.
- To divert the water to the handshower, pull up on the diverter knob. When the water is turned off, the diverter will automatically reset to the spout position.
- The handshower has two spray modes: full spray and soft. To change spray modes, turn the face ring until the indexing mark is next to the name of the desired function.
- The handshower uses the Quick-Clean!<sup>TM</sup> cleaning system. When the spray mode is changed, pins push through the regular spray channels, clearing them of any scale deposits.
- If scale deposits build up on the spray face, pour about 3/4" of a commercial scale remover, such as Lime-Away<sup>TM</sup> or CLR<sup>TM</sup>, into a shallow dish. Soak just the gray spray face in the remover for the time specified on the remover label. Do not allow the remover to sit on the finished surfaces. When finished, rinse the handshower with clear water before using.

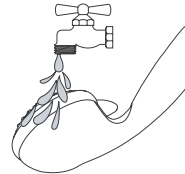
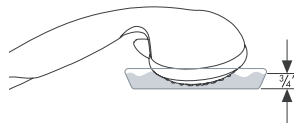
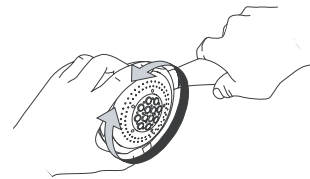

## Troubleshooting

Problem	Possible Cause	Solution
Water drips from spout when unit is turned off.	Valve cartridge is dirty or faulty.	Remove and clean valve cartridge. Replace if faulty.
Water leaks from under spout.	Set screw is too tight. Diverter is not straight.	Loosen set screw slightly Remove and reinstall diverter, pressing diverter evenly into place.
Handspray does not retract easily.	Diverter is faulty. Inner Secu-flex hose should be cleaned and lubricated.	Replace diverter. Pull out handshower. Clean and lubricate inner Secuflex hose with cloth sprayed with silicon sealant.
When handspray is pulled out, handshower holder comes off of tub.	Handshower holder not installed correctly.	Reinstall handshower holder according to installation instruction.

---

## ***Cleaning Recommendation for Hansgrohe Products***

Modern faucetry and shower products utilize a combination of materials to comply with the needs of the market with regard to design and functionality.

To avoid damage, it is necessary to use some caution when cleaning. Damage caused by improper treatment is not covered under the Hansgrohe warranty.

### ***Cleaning Materials for Faucets and Showers***

- To remove lime scale, use only products made specifically for that purpose. Always follow the manufacturer's instructions when using.
- Do not use cleaners that contain hydrochloric, formic, acetic, or phosphoric acids, as these will cause considerable damage to finishes and to plastic components.
- Never mix cleaning materials.
- Never use cleaners containing abrasives. Do not use abrasive cleaning cloths, pads, or sponges.

### ***Cleaning Procedures***

- Clean your faucets and shower products as and when required. Regular cleaning will prevent scale buildup and water spotting.
- Follow the label instructions. Do not allow any cleaner to remain on the product for longer than necessary.
- When using spray cleaners, spray first onto a sponge or cloth – do not spray directly onto the product.
- After cleaning, rinse thoroughly with clear water to remove any cleaner residue.

### ***Important***

- Soap and shampoo residue can also cause damage to the product. Rinse well with clean water after use.
- If the surface is already damaged, harsh cleaning materials will cause further damage.

## ***Limited Lifetime Consumer Warranty***

This product has been manufactured and tested to the highest quality standards by Hansgrohe, Inc. ("Hansgrohe"). This warranty is limited to Hansgrohe products which are purchased by a consumer in the United States after March 1, 1996, and installed in either the United States or Canada.

### ***WHO IS COVERED BY THE WARRANTY***

This warranty extends to the original consumer purchaser only.

### ***WHAT IS COVERED BY THE WARRANTY***

This warranty covers only your Hansgrohe manufactured product. Hansgrohe warrants this product against defects in material or workmanship as follows: Hansgrohe will repair at no charge for parts only or, at its option, replace any product or part of the product which proves defective because of improper workmanship and/or material, under normal installation, use, service and maintenance. If Hansgrohe is unable to provide a replacement and repair is not practical or cannot be timely made, Hansgrohe may elect to refund the purchase price in exchange for the return of the product.

### ***LENGTH OF WARRANTY***

Replacement or repaired parts of products will be covered for the term of this warranty as stated in the following two sentences. If you are a consumer who purchased the product for use primarily for personal, family, or household purposes, this warranty extends for as long as you own the product and the home in which the product is installed. If you purchased the product for use primarily for any other purpose, including, without limitation, a commercial purpose, this warranty extends only (i) for 1 year, with respect to Interaktiv and Retroaktiv products, and (ii) for 5 years, with respect to AXOR, ShowerPower and Pharo products.

---

***THIS WARRANTY DOES NOT COVER, AND HANSGROHE WILL NOT PAY FOR:***

- A. Conditions, malfunctions or damage not resulting from defects in material or workmanship.
- B. Conditions, malfunctions or damage resulting from (1) improper installation, improper maintenance, misuse, abuse, negligence, accident or alteration, or (2) the use of abrasive or caustic cleaning agents or "no rinse" cleaning products, or the use of the product in any manner contrary to the product instructions.
- C. Labor or other expenses for the disconnection or return of the product for warranty service, or for installation or reinstallation of the product.
- D. Accessories or related products not manufactured by Hansgrohe.

***TO OBTAIN WARRANTY SERVICE***

Contact your Hansgrohe retailer, or write to Technical Service at:

Hansgrohe Inc.  
1492 Bluegrass Lakes Parkway  
Alpharetta GA 30004

Or, call Hansgrohe toll-free at (800) 334-0455.

In requesting warranty service, you will need to provide

1. The sales receipt or other evidence of the date and place of purchase.
2. A description of the problem.
3. Delivery of the product or the defective part, postage prepaid and carefully packed and insured, to Hansgrohe Inc. 1492 Bluegrass Lakes Parkway, Alpharetta, Georgia 30004, Attention: Technical Service, if required by Hansgrohe.

When warranty service is completed, any repaired or replacement product or part will be returned to you postage prepaid.

***EXCLUSIONS AND LIMITATIONS***

***REPAIR OR REPLACEMENT (OR, IN LIMITED CIRCUMSTANCES, REFUND OF THE PURCHASE PRICE) AS PROVIDED UNDER THIS WARRANTY IS THE EXCLUSIVE REMEDY OF THE PURCHASER. HANSGROHE NEITHER ASSUMES NOR AUTHORIZES ANY PERSON TO CREATE FOR IT ANY OBLIGATION OR LIABILITY IN CONNECTION WITH THIS PRODUCT.***

***HANSGROHE SHALL NOT BE LIABLE TO PURCHASER OR ANY PERSON FOR ANY INCIDENTAL, SPECIAL, OR CONSEQUENTIAL DAMAGES, ARISING OUT OF BREACH OF THIS WARRANTY OR ANY IMPLIED WARRANTY (INCLUDING MERCHANTABILITY).***

Some States do not allow the exclusion or limitation of incidental or consequential damages, so the above limitation or exclusion may not apply to you.

This warranty gives you specific legal rights, and you may have other rights which vary from State to State.

You may be required by law to give us a reasonable opportunity to correct or cure any failure to comply before you can bring any action in court against us under the Magnuson-Moss Warranty Act.

***PRODUCT INSTRUCTIONS AND QUESTIONS***

Upon purchase or prior to installation, please carefully inspect your Hansgrohe product for any damage or visible defect. Prior to installing, always carefully study the enclosed instructions on the proper installation and the care and maintenance of the product. If you have questions at any time about the use, installation, or performance of your Hansgrohe product, or this warranty, please call or write to us at the toll-free number and address printed above.

**hansgrohe**

Hansgrohe, Inc. • 1490 Bluegrass Lakes Parkway • Alpharetta GA 30004  
Tel 770 360-9880 • Fax 770 360-9887  
[www.hansgrohe-USA.com](http://www.hansgrohe-USA.com)