

Installation Instructions / Warranty

EQUILIBRIUM PRESSURE BALANCE VALVE

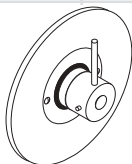

Starck
10408XX1

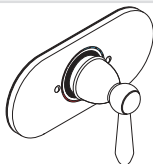

Carlton
17408XX1

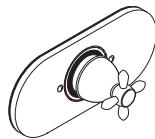

Carlton
17508XX1

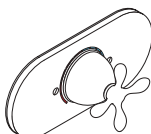

Phoenix
17417XX1

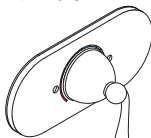

Phoenix
17418XX1

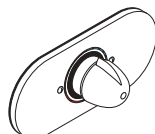

Steel
35408801

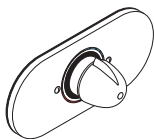

Allegroh
36408XX1

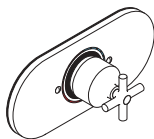

Terrano
37408XX1

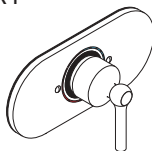

Terrano
37508XX1

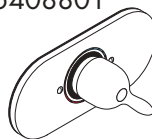

Mondial
15518XX1

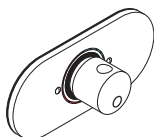

Uno
38408XX1

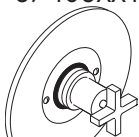

Citterio
39417XX1

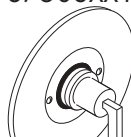

Citterio
39418XX1



**Mondial/
Metris/
Elegance/
Sportive**
15418XX1

Rough-in Ref. No.: 13408181

hansgrohe

AXOR | PHARO

Assembling

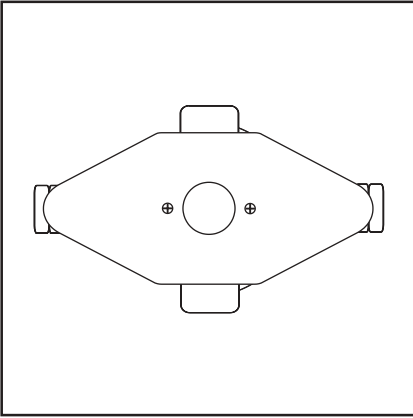

1. Remove the two screws from the finish wall template, then remove the template. Seal the wall around the rough-in body with silicone free from acetic acid (not in scope of delivery).

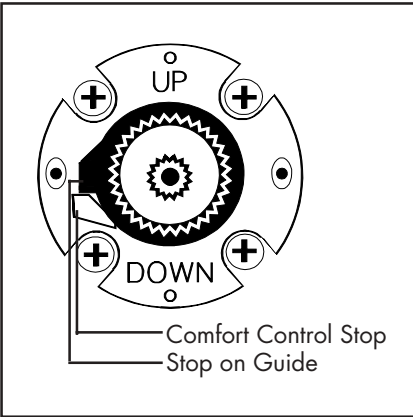

2. Stop and check valves must be in full open position.
3. Push the handle onto the stem just enough so that the valve can be opened and closed.
4. Open the valve until maximum desired hot temperature is discharging.
5. Remove the handle.

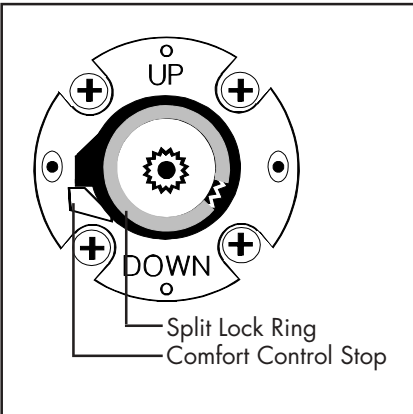

6. Place the adjustable comfort control stop over the plastic guide.
7. Push the split lock ring down over the stem until it snaps into the groove directly above the comfort control stop.
8. Close the valve.
9. Install the sleeve and the escutcheon onto the valve.

Handle assembly

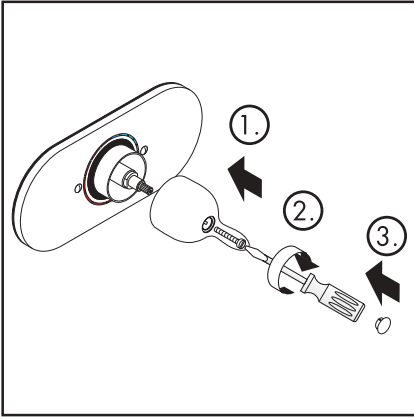

Mondial 15518XX1/
Starck 10408XX1/
Terrano 37408XX1/37508XX1

1. Push the handle onto the stem so that the handle covers the "OFF" position on the escutcheon.
2. Fix the screw.
3. Cover the hole by the plastic cap.

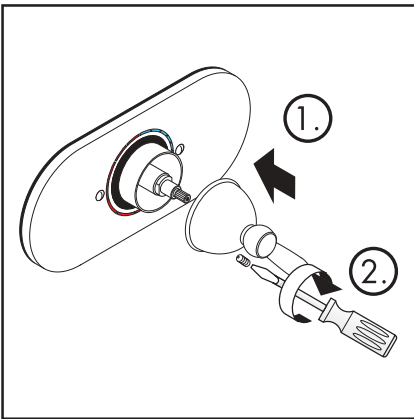

Carlton 17408XX1 / 17508XX1
Phoenix 17417XX1 / 17418XX1

1. Push the handle onto the stem so that the handle covers the "OFF" position on the escutcheon.
2. Fix the screw.

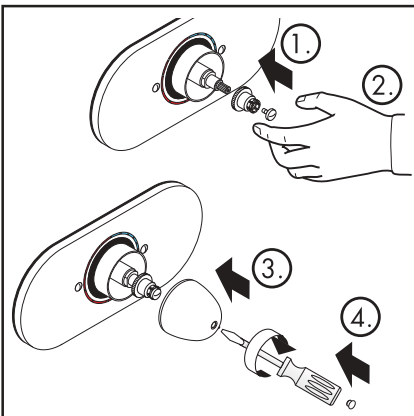

Steel 35408801
Allegroh 36408XX1
Uno 38408XX1
Mondial / Metris / Elegance / Sportive
15418XX1

1. Push the handle adapter onto the stem.
2. Lock the screw by hand only three turns.
3. Snap on the handle so that the small nose of the handle points at the "OFF" position on the escutcheon.
4. Fix the screw. Cover the hole by the plastic cap.

Handle assembly

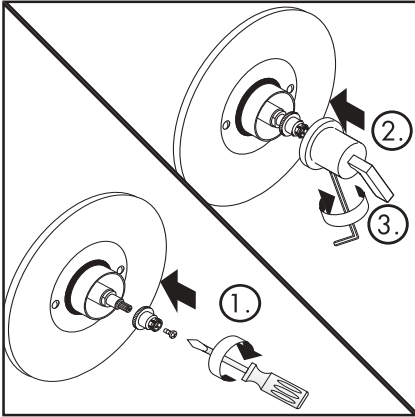

Citterio 39417XX1 / 39418XX1

1. Install the handle fixation and lock the screw.
2. Snap on the handle so that the handle covers the "OFF" position on the escutcheon.
3. Fix the hollow set screw with a hex wrench 2 mm.

Spare parts

1	escutcheon	Starck/Citterio	96544XX1
	escutcheon	Carlton/Allegroh/ Terrano/Uno/ Phoenix/Mondial/ Metris/Elegance/ Sportive	94352XX0
	escutcheon	Steel	96545801
2	screws		96096XX0
3	sleve		
4	handle	Starck	96546XX1
4.1	screw-cover	Starck	96547XX1
5	cross handle	Carlton	17993XX1
6	lever handle	Carlton	17298XX1
7	lever handle	Phoenix	96632XX1
8	handle	Steel	35993801
8.1	screw-cover	Steel/Allegroh/ Uno/Mondial/ Metris/Elegance/ Sportive	96541001
9	handle	Allegroh Mondial/Metris/ Elegance/Sportive	36993XX1
10	lever handle	Mondial	96548001
10.1	screw-cover	Mondial	96549001
11	cross handle	Terrano	37995XX1
11.1	screw-cover	Terrano	96542XX0
12	lever handle	Terrano	37993XX1
12.1	screw-cover	Terrano	96543XX0
13	handle	Uno	38993XX1
14	cross handle	Phoenix	96792XX1
15	cross handle	Citterio	39991XX1
16	lever handle	Citterio	39992XX1

XX = Color code:

00	chrome
09	chrome/gold
42	platinum
80	steel
81	satinox®
88	satín chrome

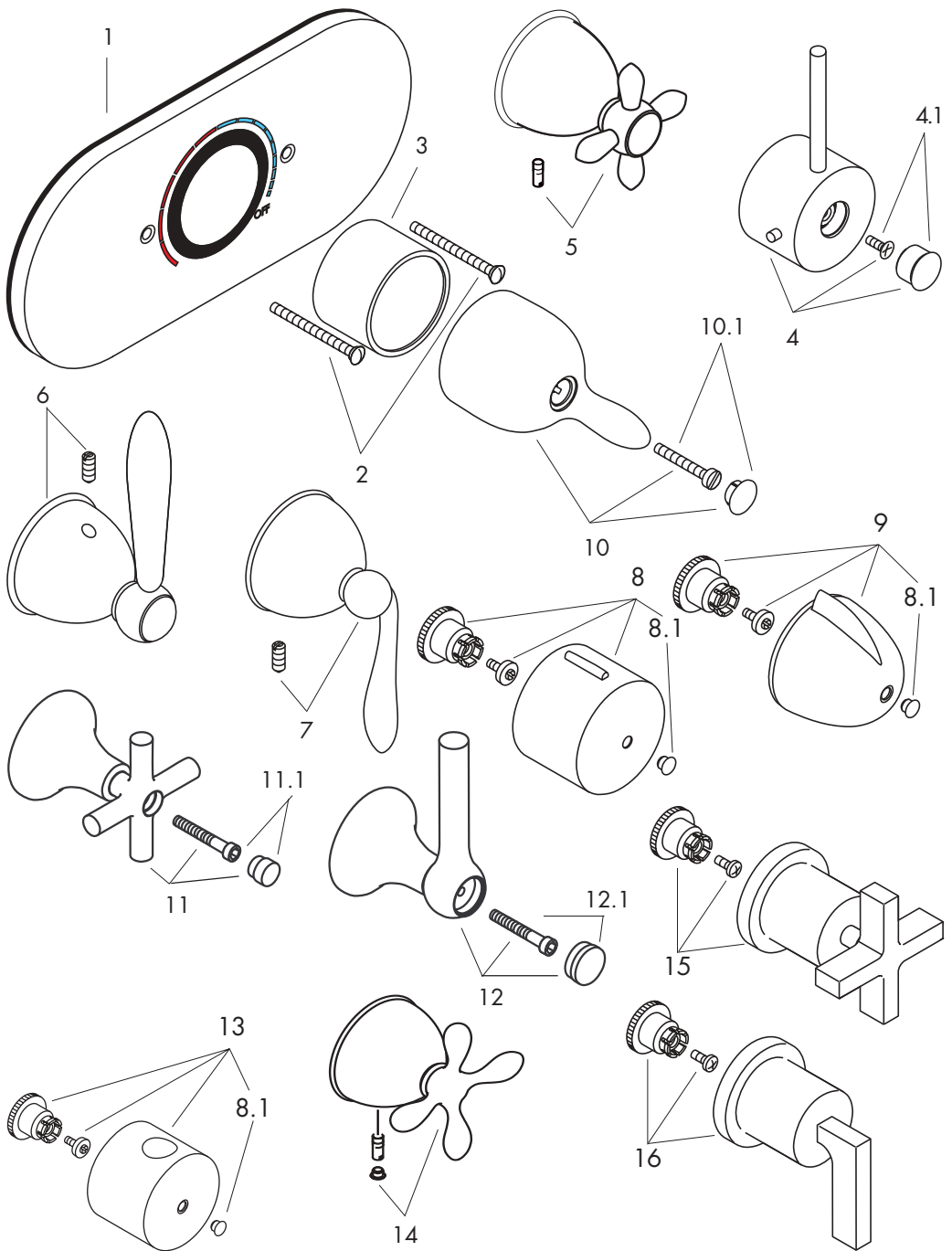

Cleaning Recommendation for Hansgrohe Products

Modern faucetry and shower products utilize a combination of materials to comply with the needs of the market with regard to design and functionality.

To avoid damage, it is necessary to use some caution when cleaning. Damage caused by improper treatment is not covered under the Hansgrohe warranty.

Cleaning Materials for Faucets and Showers

- To remove lime scale, use only products made specifically for that purpose. Always follow the manufacturer's instructions when using.
- Do not use cleaners that contain hydrochloric, formic, acetic, or phosphoric acids, as these will cause considerable damage to finishes and to plastic components.
- Never mix cleaning materials.
- Never use cleaners containing abrasives. Do not use abrasive cleaning cloths, pads, or sponges.

Cleaning Procedures

- Clean your faucets and shower products as and when required. Regular cleaning will prevent scale buildup and water spotting.
- Follow the label instructions. Do not allow any cleaner to remain on the product for longer than necessary.
- When using spray cleaners, spray first onto a sponge or cloth – do not spray directly onto the product.
- After cleaning, rinse thoroughly with clear water to remove any cleaner residue.

Important

- Soap and shampoo residue can also cause damage to the product. Rinse well with clean water after use.
- If the surface is already damaged, harsh cleaning materials will cause further damage.

Hansgrohe Consumer Warranty

Hansgrohe products are manufactured and tested to the highest quality standards. Hansgrohe, Inc. warrants to the original consumer that its products will be free from defects of workmanship and materials for as long as the original consumer owns the home in which the products are installed. Accessories or parts of products manufactured by others are warranted only for the period and to the extent of the original manufacturer's warranty.

This warranty applies only to products purchased for consumer use. Products purchased for commercial, industrial or business use are covered under a separate one-year warranty. **This warranty does not cover installation or any other labor charges associated with the repair or reinstallation of Hansgrohe products. This express warranty does not apply to products that have been damaged due to misuse, abuse, negligence, accident, faulty installation, use of abrasive or caustic cleaners, poor maintenance practices or use in any manner contrary to the written instructions provided.**

Hansgrohe, Inc. will repair or replace, at its option, free of charge during the warranty period, any part which proves to be defective in material and/or workmanship under normal installation, use, service and maintenance. If Hansgrohe, Inc. is unable to provide a replacement and repair is not practical or cannot be made in a timely manner, Hansgrohe, Inc. will refund the purchase price in exchange for return of the product. THIS REMEDY IS THE SOLE AND EXCLUSIVE REMEDY TO THE PURCHASER FOR THE BREACH OF ANY WARRANTIES OR NEGLIGENCE BY HANSGROHE, INC.

For assistance, simply notify your Hansgrohe dealer or write to: Customer Service, Hansgrohe, Inc., 1490 Bluegrass Lakes Pkwy, Alpharetta, GA 30004. Include the original receipt with a description of problem, model number and your name and address. Hansgrohe may, at its option, require you to send the defective part of the product prepaid for inspection prior to replacement.

This warranty is limited to the above; and this warranty and any warranties implied by state law, including the implied warranty of merchantability, apply only to products purchased after March 1, 1996. This warranty gives you specific legal rights; you may also have other rights which vary from state to state. Unless otherwise contrary to state law governing the purchase, Hansgrohe, Inc. liability will not exceed the contract price for the product claimed to be defective or unsuitable and is applicable only to products purchased through Hansgrohe, Inc. and installed in the United States or Canada.

hansgrohe

AXOR | PHÂRO

Hansgrohe Inc. 1490 Bluegrass Lakes Parkway Alpharetta GA 30004
Phone 770 360 9880 Internet www.Hansgrohe-USA.com

08/2003
9.086616.08