

Installation Instructions / Warranty

TRIO STOP THREE WAY DIVERTER Trim sets

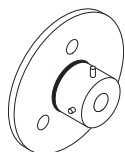

Starck
10885XX1



Carlton
17885XX1



Carlton
17886XX1



Phoenix
17894XX1



Phoenix
17895XX1

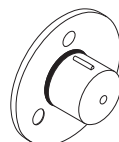

Steel
35885801



Allegroh
36885XX1



Terrano
37885XX1



Terrano
37886XX1

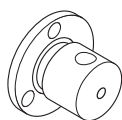

Uno
38885XX1

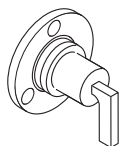

Citterio
39895XX1

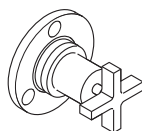

Citterio
39894XX1



**Mondial/
Metris/
Elegance/
Sportive**
15985XX1

Rough-in Ref. No.: 15980181

hangrohe

AXOR | PHARO

Starck
10885XX1

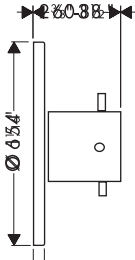

Carlton
17885XX1

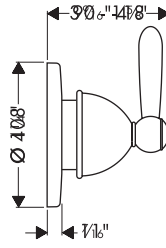

Carlton
17886XX1

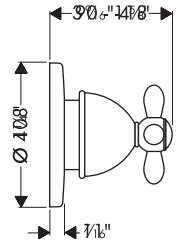

Phoenix
17894XX1

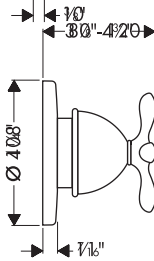

Phoenix
17895XX1

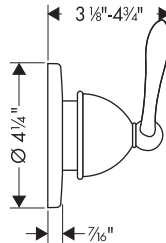

Steel
35885801

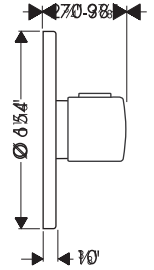

Allegroh
36885XX1

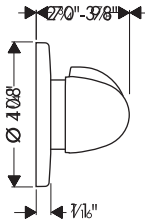

Terrano
37885XX1

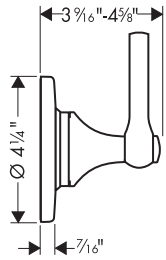

Terrano
37886XX1

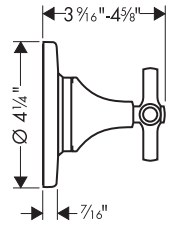

Uno Novo
38885XX1

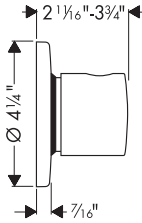

Citterio
39895XX1

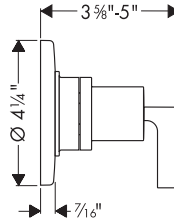

Citterio
39894XX1

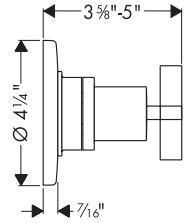

**Mondial/
Metris/
Elegance/
Sportive**
15985XX1

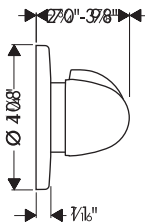

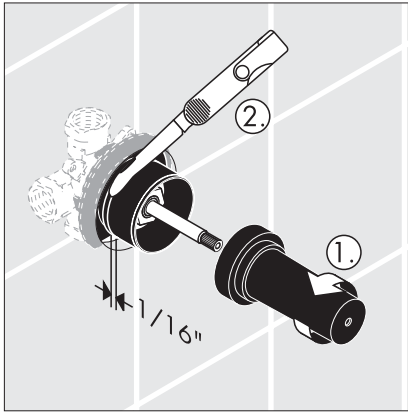

Sleeve and escutcheon assembly

1. Remove the cover
2. Shorten the plastic body 1/16" in front of the tiles

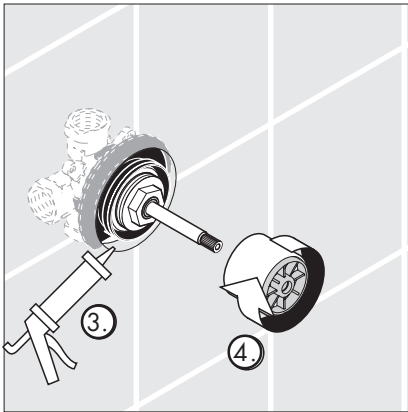

3. Seal around the rough-in with waterproof bathroom sealant
4. Install the sleeve

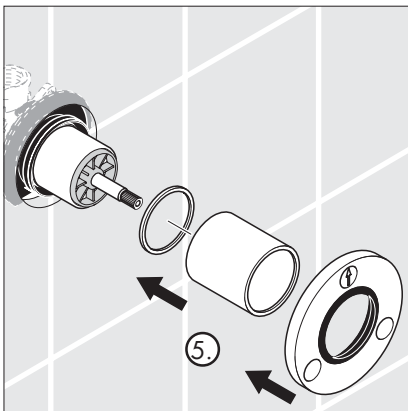

5. Install the trim sleeve and the escutcheon.

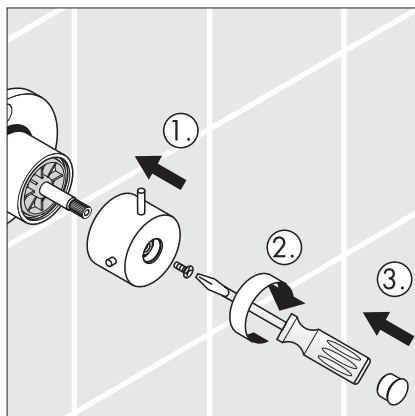

Handle assembly

10885XX1 Starck
37885XX1 / 37886XX1 Terrano

1. Push the handle onto the shaft.
2. Fix the screw.
3. Cover the hole by the plastic cap.

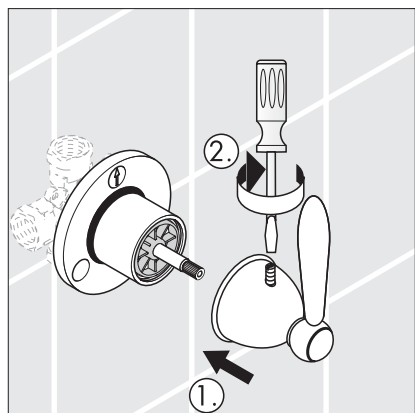

17885XX1 / 17886XX1 Carlton
17894XX1 / 17895XX1 Phoenix

1. Push the handle onto the shaft.
2. Fix the screw.

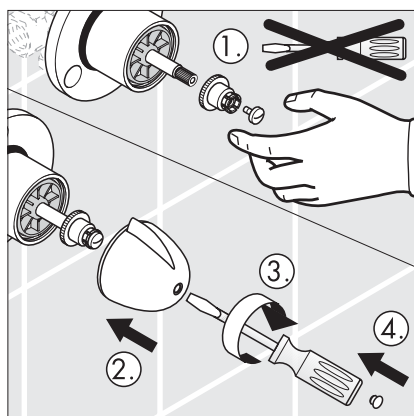

35885801 Steel
36885XX1 Allegroh
38885XX1 Uno
15985XX1 Mondial/Metris/Elegance/Sportive

1. Lock the screw by hand only three turns.
2. Snap on the handle.
3. Fix the screw.
4. Cover the hole by the plastic cap.

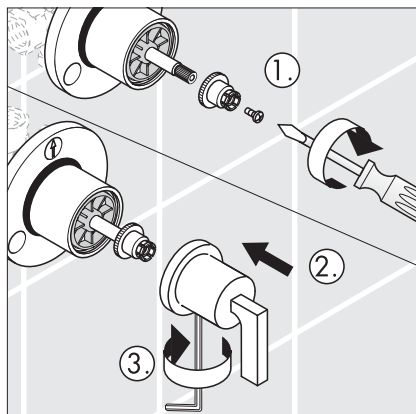

Citterio 39920XX1 / 39925XX1

1. Install the handle fixation and lock the screw.
2. Snap on the handle.
3. Fix the hollow set screw with a hex wrench 2 mm.

Spare parts

1	escutcheon escutcheon	Starck Starck/Carlton/Phoenix/Steel/Allegroh/Terrano/Citterio/Uno/ Mondial/Metris/Elegance/Sportive	94356XX0 13936XX0
2	sleeve		96242XX0
3	sleeve		96431000
4	handle	Starck	10993XX1
4.1	screw-cover	Starck	96540XX1
5	cross handle	Carlton	17993XX1
6	lever handle	Carlton	17298XX1
7	handle	Steel	35993801
7.1	screw-cover	Steel/Allegroh/Uno/Mondial/Metris/ Elegance/Sportive/Phoenix cross handle	96541001
8	handle	Allegroh Mondial/Metris/Elegance/Sportive	36993XX1 37995XX1
9	cross handle	Terrano	96542XX0
9.1	screw-cover	Terrano	37993XX1
10	lever handle	Terrano	96543XX0
10.1	screw-cover	Terrano	38993XX1
11	handle	Uno	96632XX1
12	lever handle	Phoenix	96792XX1
13	cross handle	Phoenix	39993XX1
14	lever handle	Citterio	39995XX1
15	cross handle	Citterio	

XX = Color code:

- 00 chrome
- 09 chrome/gold
- 42 platin
- 80 steel
- 81 satinox
- 88 satin chrome

Extension Set 1 1/2" 96241000 (If needed, please order separately)

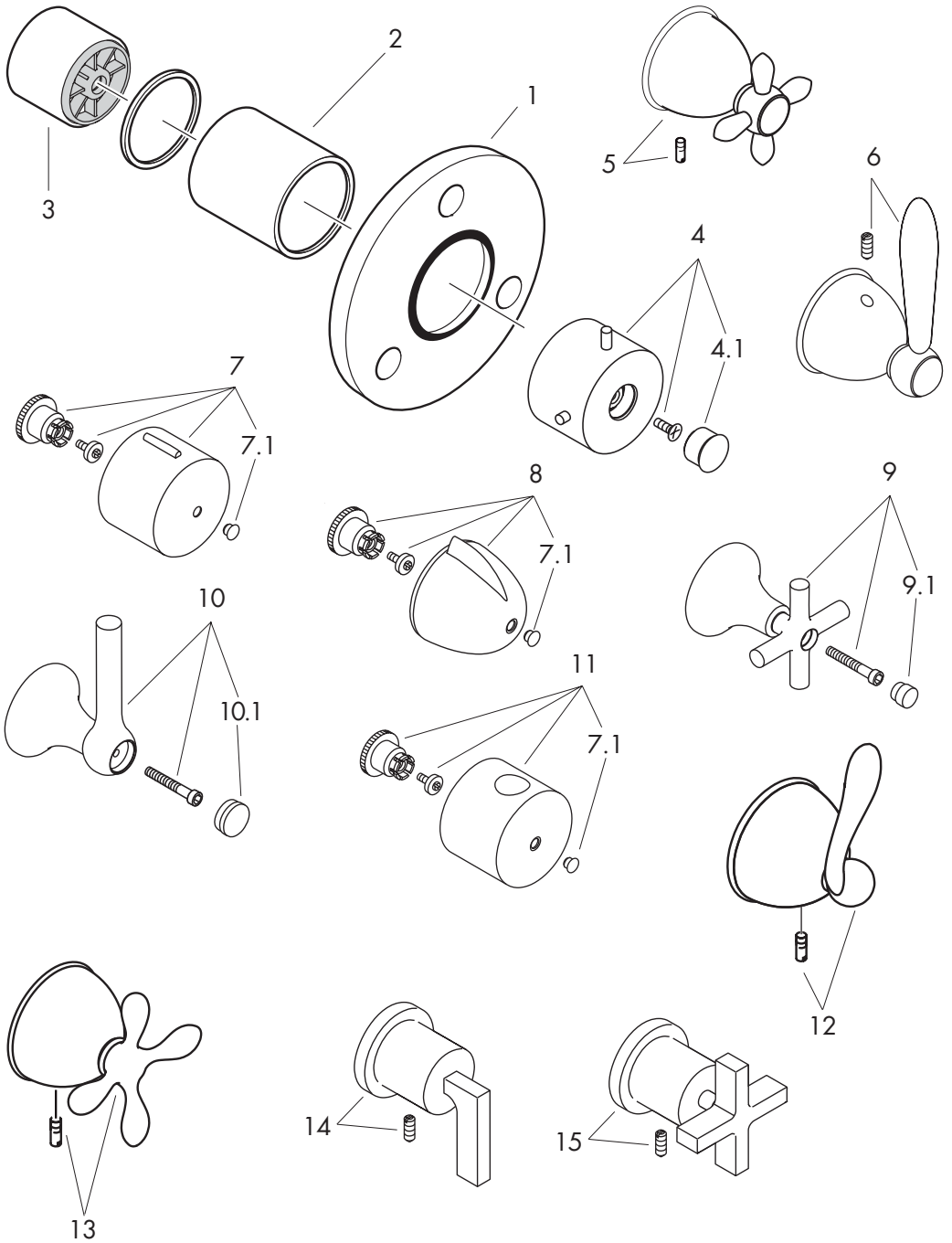

Cleaning Recommendation for Hansgrohe Products

Modern faucetry and shower products utilize a combination of materials to comply with the needs of the market with regard to design and functionality.

To avoid damage, it is necessary to use some caution when cleaning. Damage caused by improper treatment is not covered under the Hansgrohe warranty.

Cleaning Materials for Faucets and Showers

- To remove lime scale, use only products made specifically for that purpose. Always follow the manufacturer's instructions when using.
- Do not use cleaners that contain hydrochloric, formic, acetic, or phosphoric acids, as these will cause considerable damage to finishes and to plastic components.
- Never mix cleaning materials.
- Never use cleaners containing abrasives. Do not use abrasive cleaning cloths, pads, or sponges.

Cleaning Procedures

- Clean your faucets and shower products as and when required. Regular cleaning will prevent scale buildup and water spotting.
- Follow the label instructions. Do not allow any cleaner to remain on the product for longer than necessary.
- When using spray cleaners, spray first onto a sponge or cloth – do not spray directly onto the product.
- After cleaning, rinse thoroughly with clear water to remove any cleaner residue.

Important

- Soap and shampoo residue can also cause damage to the product. Rinse well with clean water after use.
- If the surface is already damaged, harsh cleaning materials will cause further damage.

Limited Lifetime Consumer Warranty

This product has been manufactured and tested to the highest quality standards by Hansgrohe, Inc. („Hansgrohe“). This warranty is limited to Hansgrohe products which are purchased by a consumer in the United States after March 1, 1996, and installed in either the United States or Canada.

WHO IS COVERED BY THE WARRANTY

This warranty extends to the original consumer purchaser only.

WHAT IS COVERED BY THE WARRANTY

This warranty covers only your Hansgrohe manufactured product. Hansgrohe warrants this product against defects in material or workmanship as follows: Hansgrohe will repair at no charge for parts only or, at its option, replace any product or part of the product which proves defective because of improper workmanship and/or material, under normal installation, use, service and maintenance. If Hansgrohe is unable to provide a replacement and repair is not practical or cannot be timely made, Hansgrohe may elect to refund the purchase price in exchange for the return of the product.

LENGTH OF WARRANTY

Replacement or repaired parts of products will be covered for the term of this warranty as stated in the following two sentences. If you are a consumer who purchased the product for use primarily for personal, family, or household purposes, this warranty extends for as long as you own the product and the home in which the product is installed. If you purchased the product for use primarily for any other purpose, including, without limitation, a commercial purpose, this warranty extends only (i) for 1 year, with respect to Interaktiv and Retroaktiv products, and (ii) for 5 years, with respect to AXOR, ShowerPower and Pharo products.

THIS WARRANTY DOES NOT COVER, AND HANSGROHE WILL NOT PAY FOR:

- A. Conditions, malfunctions or damage not resulting from defects in material or workmanship.
- B. Conditions, malfunctions or damage resulting from (1) improper installation, improper maintenance, misuse, abuse, negligence, accident or alteration, or (2) the use of abrasive or caustic cleaning agents or „no rinse“ cleaning products, or the use of the product in any manner contrary to the product instructions.
- C. Labor or other expenses for the disconnection or return of the product for warranty service, or for installation or reinstallation of the product.
- D. Accessories or related products not manufactured by Hansgrohe.

TO OBTAIN WARRANTY SERVICE

Contact your Hansgrohe retailer, or write to Technical Service at:

Hansgrohe Inc.
1492 Bluegrass Lakes Parkway
Alpharetta GA 30004

Or, call Hansgrohe toll-free at (800) 334-0455.

In requesting warranty service, you will need to provide

1. The sales receipt or other evidence of the date and place of purchase.
2. A description of the problem.
3. Delivery of the product or the defective part, postage prepaid and carefully packed and insured, to Hansgrohe Inc. 1492 Bluegrass Lakes Parkway, Alpharetta, Georgia 30004, Attention: Technical Service, if required by Hansgrohe.

When warranty service is completed, any repaired or replacement product or part will be returned to you postage prepaid.

EXCLUSIONS AND LIMITATIONS

REPAIR OR REPLACEMENT (OR, IN LIMITED CIRCUMSTANCES, REFUND OF THE PURCHASE PRICE) AS PROVIDED UNDER THIS WARRANTY IS THE EXCLUSIVE REMEDY OF THE PURCHASER. HANSGROHE NEITHER ASSUMES NOR AUTHORIZES ANY PERSON TO CREATE FOR IT ANY OBLIGATION OR LIABILITY IN CONNECTION WITH THIS PRODUCT.

HANSGROHE SHALL NOT BE LIABLE TO PURCHASER OR ANY PERSON FOR ANY INCIDENTAL, SPECIAL, OR CONSEQUENTIAL DAMAGES, ARISING OUT OF BREACH OF THIS WARRANTY OR ANY IMPLIED WARRANTY (INCLUDING MERCHANTABILITY).

Some States do not allow the exclusion or limitation of incidental or consequential damages, so the above limitation or exclusion may not apply to you.

This warranty gives you specific legal rights, and you may have other rights which vary from State to State.

You may be required by law to give us a reasonable opportunity to correct or cure any failure to comply before you can bring any action in court against us under the Magnuson-Moss Warranty Act.

PRODUCT INSTRUCTIONS AND QUESTIONS

Upon purchase or prior to installation, please carefully inspect your Hansgrohe product for any damage or visible defect. Prior to installing, always carefully study the enclosed instructions on the proper installation and the care and maintenance of the product. If you have questions at any time about the use, installation, or performance of your Hansgrohe product, or this warranty, please call or write to us at the toll-free number and address printed above.



hansgrohe

AXOR | PHÂRO

Hansgrohe Inc. 1490 Bluegrass Lakes Parkway Alpharetta GA 30004
Phone 770 360 9880 Internet www.Hansgrohe-USA.com

07/2004
9.08608.08