

CRT-AM COMPUTER STAND

INSTALLATION INSTRUCTIONS

Illustration 1

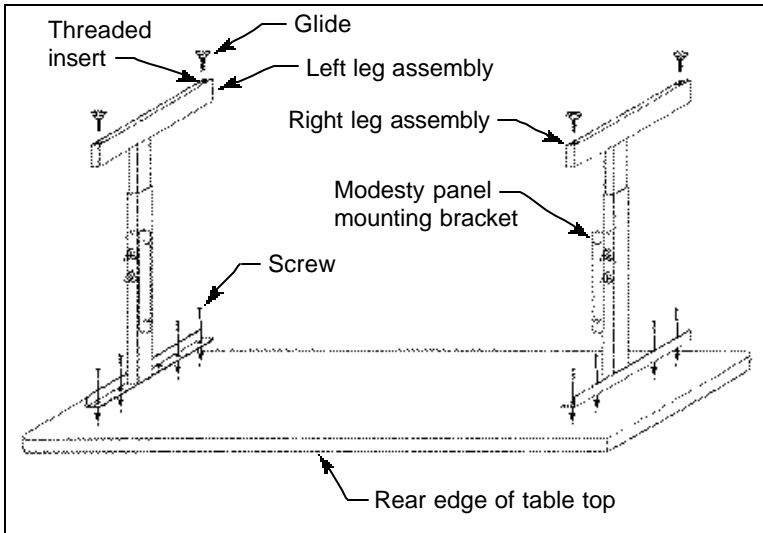
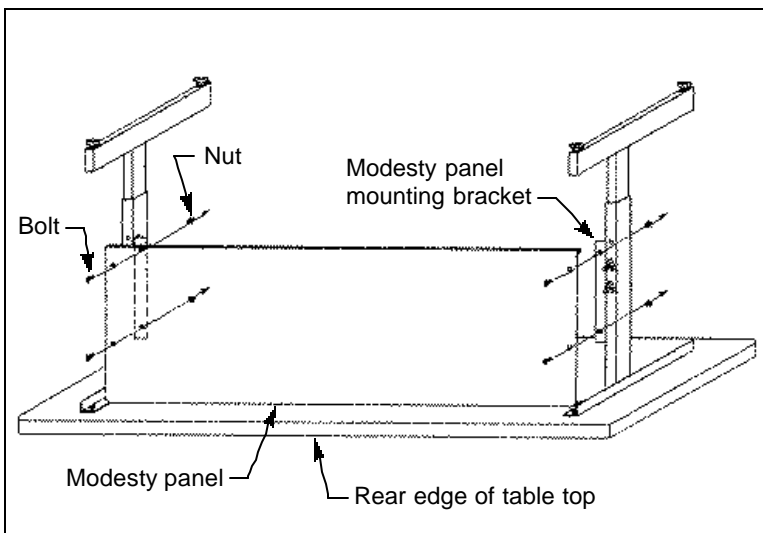

Illustration 2



Read all instructions and review illustrations before installing.

Tools required for assembly:
Power screwdriver
Safety glasses
Phillips bit
 $\frac{7}{16}$ " wrench

This assembly includes:
(1) Table top
(1) Left leg assembly
(1) Right leg assembly
(1) Modesty panel
(8) Screw
(4) Glide
(4) Bolt
(4) Nut

⚠ WARNING

Sharp edges may cause injury. Take care when handling metal parts.

To prevent the possibility of serious eye injury, always wear eye protection when using power tools.

Installation:

1. Refer to Illustration 1. Use two or more people to lay table top, upside down, on cardboard or a carpeted surface.
2. Refer to Illustration 1. Identify left leg assembly and position leg assembly over pilot holes on left side of table top. Ensure modesty panel mounting bracket faces toward center of table top.
3. Refer to Illustration 1. Use the power screwdriver and Phillips bit to install four screws (from hardware pack) through leg mounting bracket and into table top pilot holes. Fully tighten screws.
4. Refer to Illustration 1. Position right leg assembly over pilot holes on right side of table top. Ensure modesty panel mounting bracket faces toward center of table top.
5. Refer to Illustration 1. Use the power screwdriver and Phillips bit to install four screws (from hardware pack) through leg mounting bracket and into table top pilot holes. Fully tighten screws.
6. Refer to Illustration 1. locate threaded inserts on bottom edge of each leg assembly. Thread a glide (from hardware pack) into each threaded insert. Turn glides clockwise until glides are flat against threaded inserts.
7. Refer to Illustration 2. Position modesty panel between leg assemblies as shown. Insert bolts (from hardware pack) through holes in modesty panel and into holes in modesty panel mounting brackets.
8. Refer to Illustration 2. Thread a nut (from hardware pack) onto each bolt and use the $\frac{7}{16}$ " wrench to fully tighten.

CRT-AM COMPUTER STAND

Illustration 3

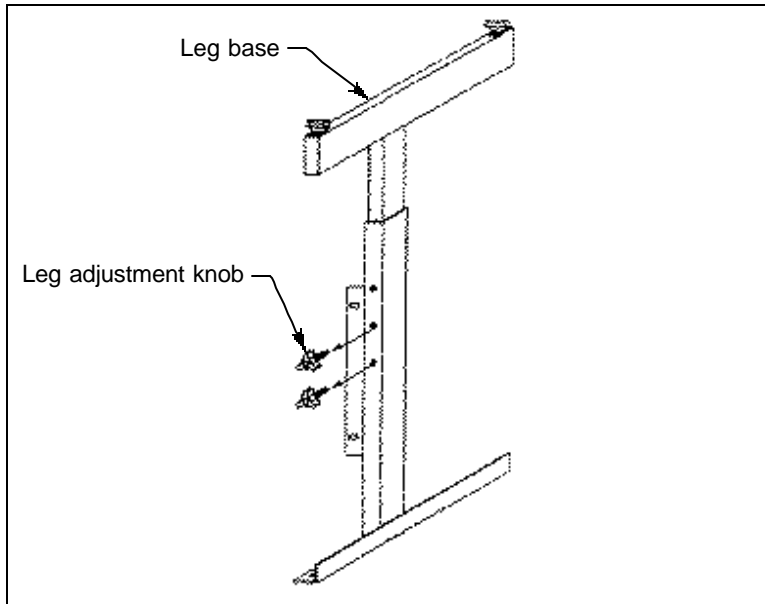

NOTE

Leg assemblies can be adjusted from 25 $\frac{1}{2}$ " high to a height of 32 $\frac{1}{2}$ ". Leg assemblies are factory set at 28 $\frac{1}{2}$ " high.

9. Refer to Illustration 3. While supporting leg base with one hand, remove leg adjustment knobs from leg assembly.
10. Refer to Illustration 3. Adjust leg base to desired height and reinstall leg adjustment knobs. Fully tighten knobs.
11. Repeat Steps 9 and 10 for remaining leg assembly. Ensure leg assemblies are evenly adjusted.
12. Use two or more people to set table upright and to position table.
13. Adjust glides to level table.