

# CORNER SLEEVE

# INSTALLATION INSTRUCTIONS

## ⚠ WARNING

Failure to install product as instructed, use of hardware other than that which is provided with the product, or failure to comply with all instructions can result in personal injury.

### Illustration 1. Corner Sleeve Installation:

Corner Sleeve Hardware Includes:  
(2) Small wood screws

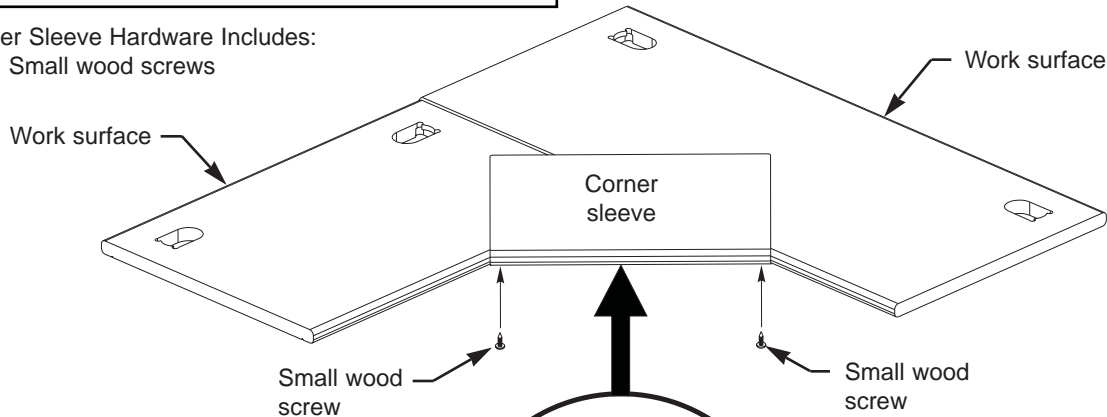

#### Installation:

1. Position corner sleeve onto adjoining tops as shown.
2. Refer to Detail A. Ensure the distances measured at points A and B are equal.
3. Install small wood screws through corner sleeve holes and into tops.

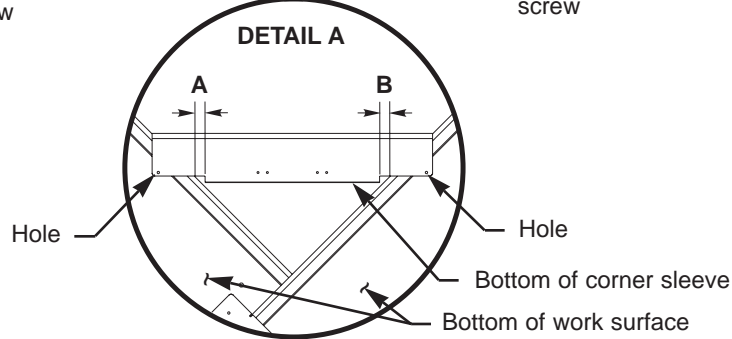

### Illustration 2. Articulating Keyboard Installation:

Articulating Keyboard Hardware Includes:  
(2) Sheet metal screws  
(4) Flat head wood screws (use as needed)

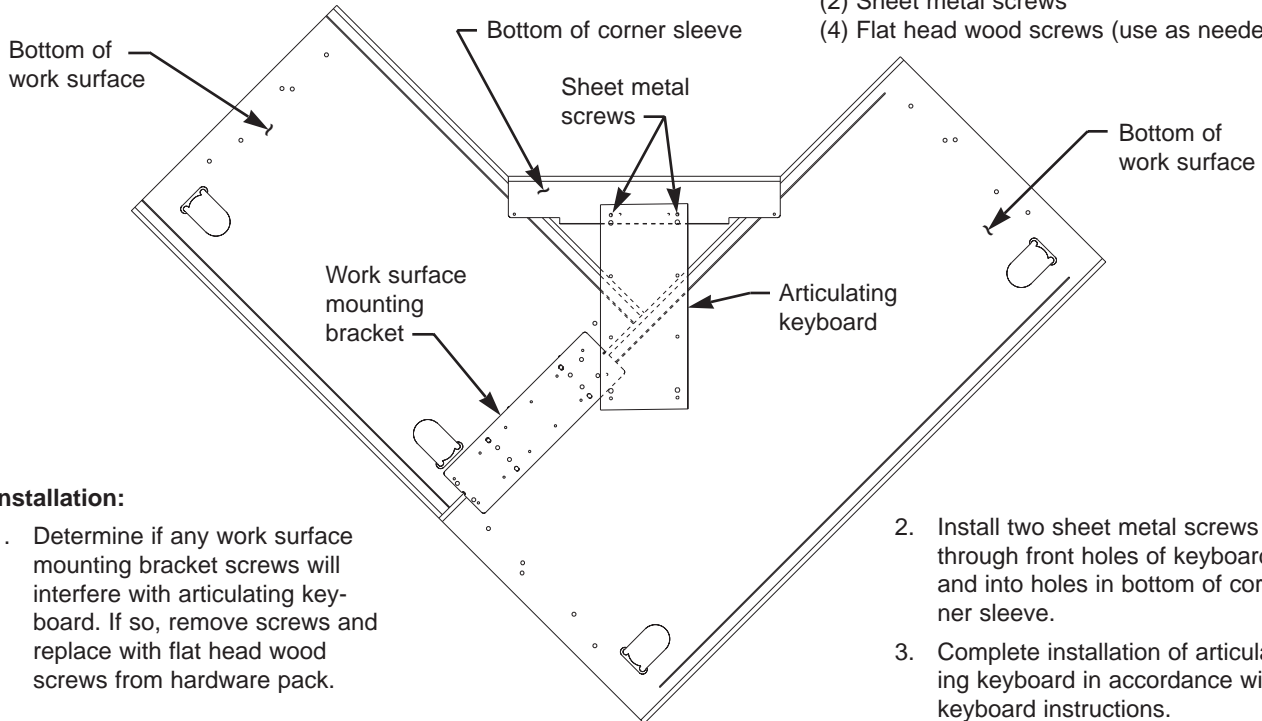

#### Installation:

1. Determine if any work surface mounting bracket screws will interfere with articulating keyboard. If so, remove screws and replace with flat head wood screws from hardware pack.
2. Install two sheet metal screws through front holes of keyboard and into holes in bottom of corner sleeve.
3. Complete installation of articulating keyboard in accordance with keyboard instructions.