

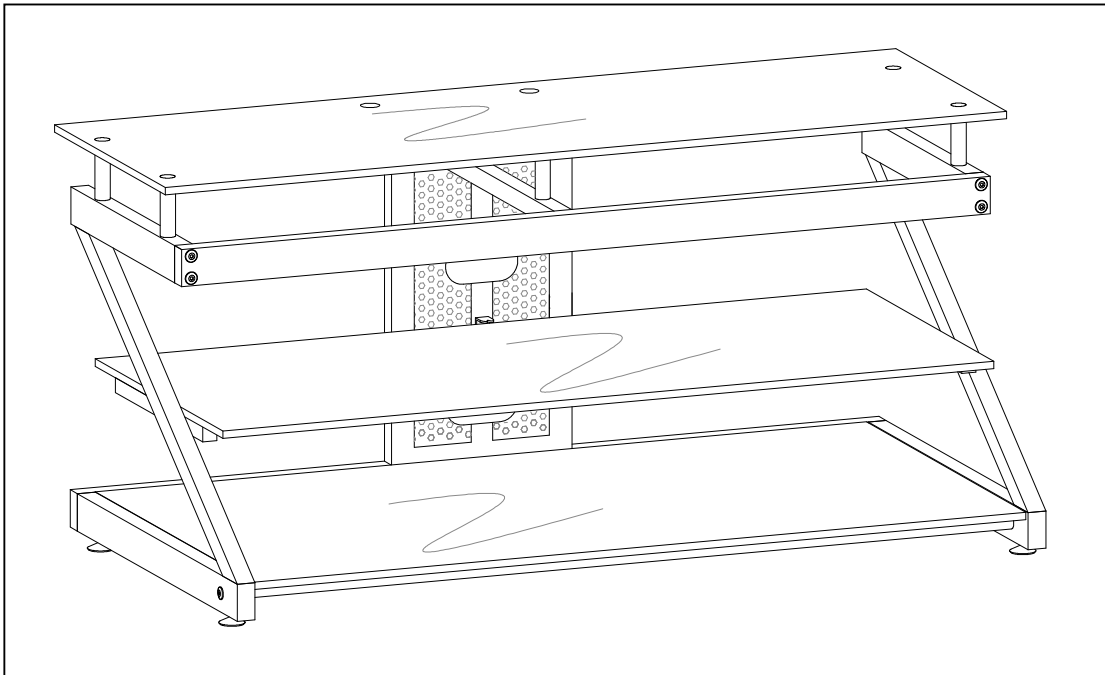

## Escalante 40"W TV Stand

**ZLN # ZL23-40SU**



**⚠ DO NOT return to the store if parts are missing or damaged.**

For Parts Replacements and Inquiries, please call us Toll-Free 1-888-736-2141 or E-mail

[CustomerService@Z-LineDesigns.com](mailto:CustomerService@Z-LineDesigns.com).

To ensure a timely delivery, please include the following:

1. Full Name
2. Physical Address (Our primary carrier, FedEx, will NOT deliver to P.O. Boxes)
3. Phone Number
4. QC Number: SW \_\_\_\_\_
5. ZLN Number: ZL23-40SU
6. Part Number(s) or Letter(s)
7. Quantity
8. We also request that you please provide a brief description of the reason for your request.

**Our Customer Service Representatives will be available to assist you Monday – Friday 7:00 am to 3:30 pm Pacific Standard Time (Except Holidays).**

043008

# Important





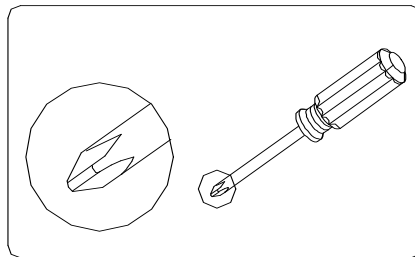





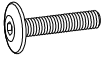

**Before you begin:** Open, identify, and count all parts prior to assembly. Lay out on non-abrasive surface. You will need the parts identified on page 3 & 4 of this instruction manual.

**NECESSARY TOOLS** – YOU WILL NEED PHILLIPS HEAD SCREW DRIVER FOR ASSEMBLY





NOW YOU ARE READY TO BEGIN ACTUAL ASSEMBLY!

## HARDWARE IDENTIFICATION







A		FLOOR LEVELER (FL815)	4 PCS
B		6 x 40 x 16mm ALLEN BOLT (AB64016S)	10 PCS
C		6 x 35 x 10mm ALLEN BOLT (AB63510S)	2 PCS
D		6 x 30 x 10mm ALLEN BOLT (AB63010S)	2 PCS
E		6 x 10 x 10mm ALLEN BOLT (AB61010S)	3 PCS
F		4mm ALLEN WRENCH (AW4S)	1 PC
G		4 x 8 x 8mm MACHINE SCREW (MS488S)	4 PCS
I		4 x 8 x 8mm SHELF PIN MACHINE SCREW (MSFH488S)	1 PC
J		SHELF PIN CAP NUT (CN47S)	1 PC
K		SHELF PIN BRACKET	1 PC
L		SHELF PIN SCREW W/RUBBER STOPPER	1 PC
M		7mm SPANNER (S7S)	1 PC
N		PLASTIC GLASS SUPPORT	9 PCS
O		NAME PLATE	1 PC

\*Extra hardware is enclosed for your convenience.

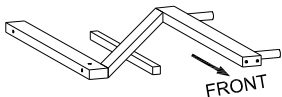
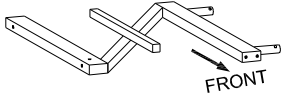
THE BELOW PARTS ARE PRE-ASSEMBLED AND ARE LISTED AS A REFERENCE ONLY.

P		BACK LOWER CONNECTOR	2 PCS
Q		WOOD SCREW (RHWS4810BL)	4 PCS

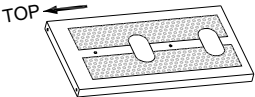
## PARTS IDENTIFICATION

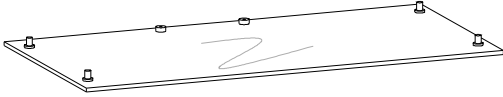
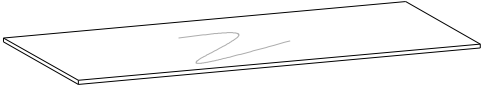
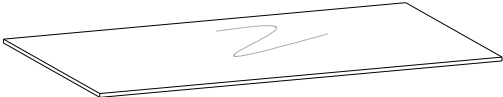
①	 <p>Diagram showing the left side frame assembly with an arrow pointing to the front edge.</p>	LEFT SIDE FRAME	1 PC
②	 <p>Diagram showing the right side frame assembly with an arrow pointing to the front edge.</p>	RIGHT SIDE FRAME	1 PC
③	 <p>Diagram of the top front panel.</p>	TOP FRONT PANEL	1 PC
④	 <p>Diagram of the bottom back panel.</p>	BOTTOM BACK PANEL	1 PC
⑤	 <p>Diagram of the bottom front crossbar.</p>	BOTTOM FRONT CROSSBAR	1 PC
⑥	 <p>Diagram of the back panel with an arrow pointing to the top edge.</p>	BACK PANEL	1 PC
⑦	 <p>Diagram of the connector.</p>	CONNECTER	1 PC
⑧	 <p>Diagram of the top glass shelf.</p>	TOP GLASS SHELF	1 PC
⑨	 <p>Diagram of the middle glass shelf.</p>	MIDDLE GLASS SHELF	1 PC
⑩	 <p>Diagram of the lower glass shelf.</p>	LOWER GLASS SHELF	1 PC

# ASSEMBLY INSTRUCTION

## STEP 1



Connect (A) Floor Levelers to (1) Left Side Frame and (2) Right Side Frame.

## STEP 2

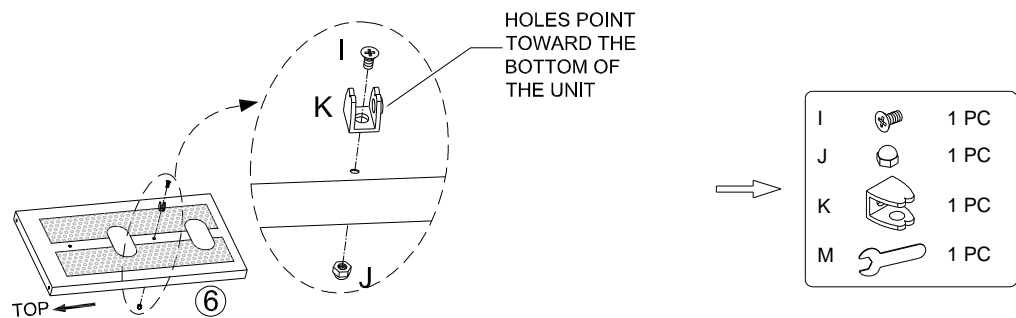

Secure (K) Shelf Pin Bracket to (6) Back Panel with (I) 4 x 8 x 8mm Shelf Pin Machine Screw and (J) Shelf Pin Cap Nut. **TIGHTEN FULLY.**

## STEP 3

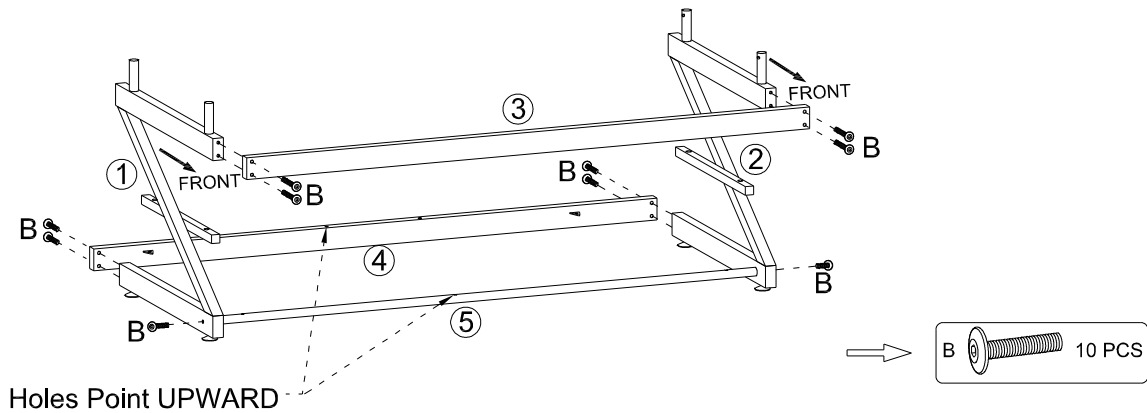

**DO NOT FULLY TIGHTEN ALLEN BOLTS UNTIL THE END OF STEP 6.**

1. Connect (5) Bottom Front Crossbar to (1) Left Side Frame and (2) Right Side Frame using (B) 6 x 40 x 16mm Allen Bolts. **\*Note: Make sure the holes to attach (N) Plastic Glass Supports (in Step 7) point UPWARD.**
2. Attach (3) Top Front Panel to (1) Left Side Frame and (2) Right Side Frame using (B) 6 x 40 x 16mm Allen Bolts. **\*Note: Make sure the holes to connect (7) Connector (in Step 4) face toward the BACK of the unit.**
3. Now attach (4) Bottom Back Panel to (1) Left Side Frame and (2) Right Side Frame using (B) 6 x 40 x 16mm Allen Bolts. **\*Note: Make sure the holes to connect (6) Back Panel (in Step 5) point UPWARD and the Glass Support Ledges face the INSIDE of the unit.**

## STEP 4

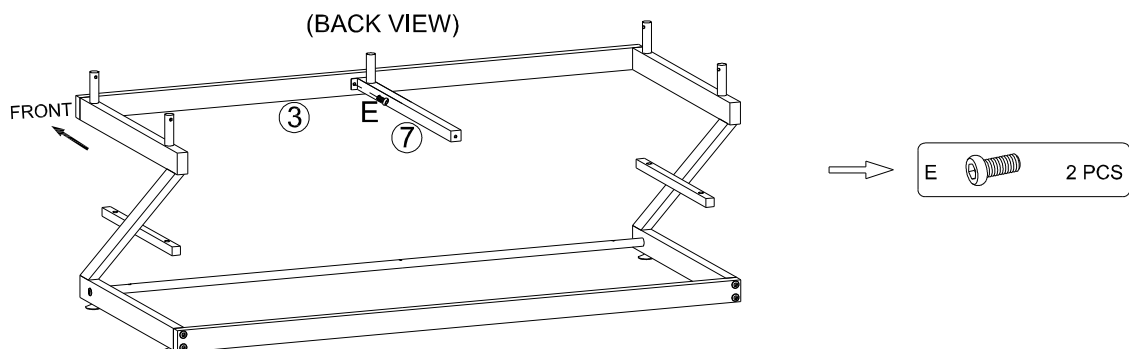

**DO NOT FULLY TIGHTEN ALLEN BOLTS UNTIL THE END OF STEP 6.**

Attach (7) Connector to (3) Top Front Panel using (E) 6 x 10 x 10mm Allen Bolts as shown.

## STEP 5

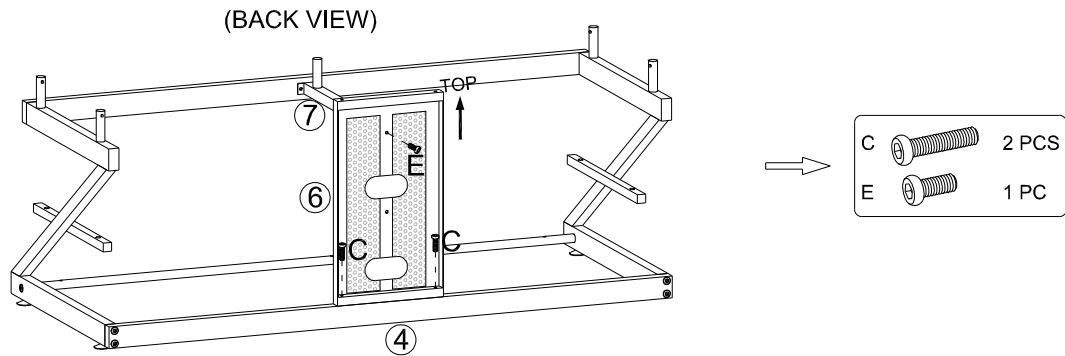

**DO NOT FULLY TIGHTEN ALLEN BOLTS UNTIL THE END OF STEP 6.**

1. Set (6) Back Panel in place with the Pre-Assembled Shelf Pin facing the **INSIDE** of the unit and the Wire Management Holes closer to the **BOTTOM** of the unit as shown.
2. Attach (6) Back Panel to (7) Connector using (E) 6 x 10 x 10mm Allen Bolt.
3. Now connect (6) Back Panel to (4) Bottom Back Panel using (C) 6 x 35 x 10mm Allen Bolts as shown.

## STEP 6

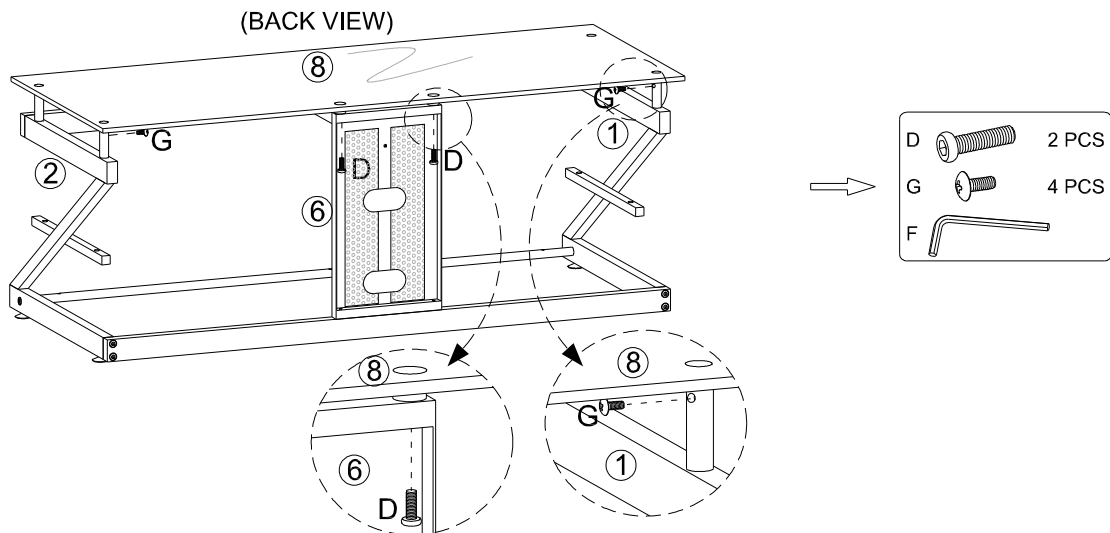

**DO NOT FULLY TIGHTEN ALLEN BOLTS UNTIL THE END OF THIS STEP.**

1. Carefully set (8) Top Glass Shelf in place as shown. **\*Note: The Cylinders attached to the glass will slide into the Connector Tubes attached to the frame.**
2. Now Secure (8) Top Glass Shelf to (1) Left Side Frame and (2) Right Side Frame using (G) 4 x 8 x 8mm Machine Screws, and to (6) Back Panel using (D) 6 x 30 x 10mm Allen Bolts as shown.
3. **TIGHTEN DOWN ALL ALLEN BOLTS AND MACHINE SCREWS.**

## STEP 7

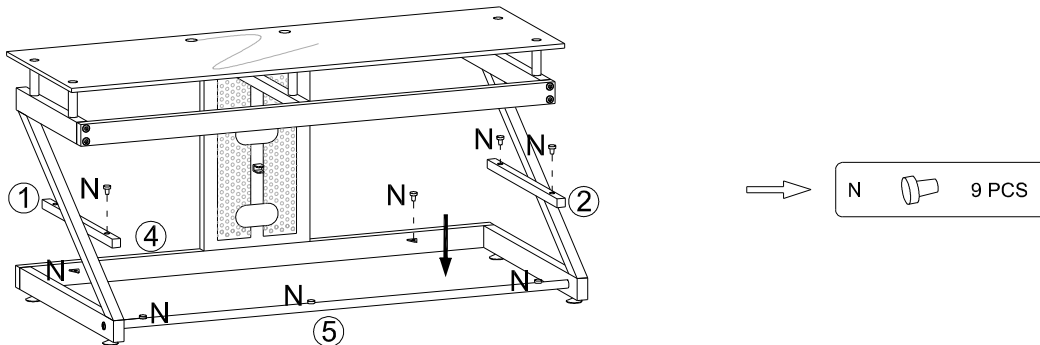

Insert (N) Plastic Glass Supports into provided holes on (1) Left Side Frame (Insert Two), (2) Right Side Frame (Insert Two), (4) Bottom Back Panel (Insert Two), and (5) Bottom Front Crossbar (Insert Three).

## STEP 8

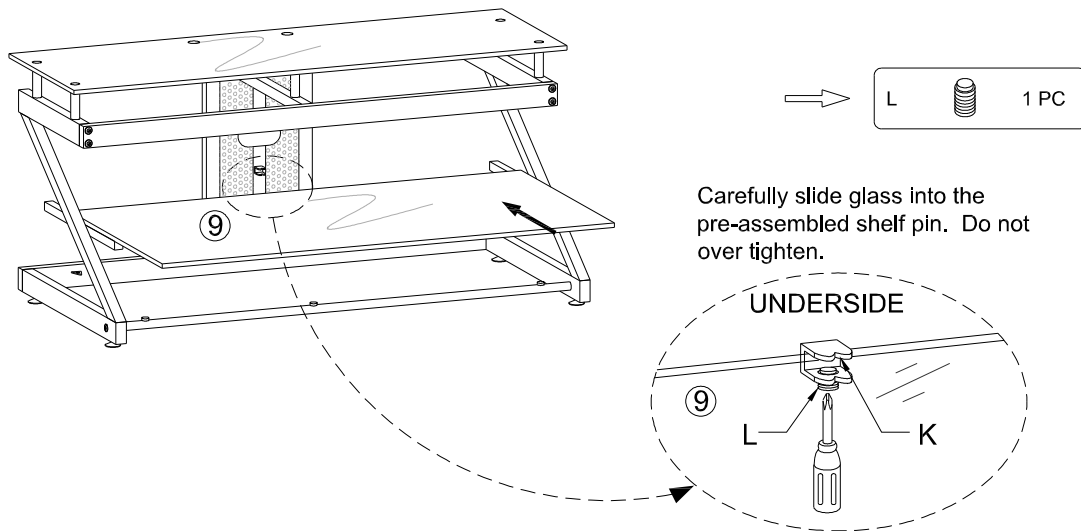

1. Carefully set (9) Middle Glass Shelf into the Pre-Assembled (K) Shelf Pin Bracket in the MIDDLE position as shown.
2. Tighten Pre-Assembled (L) Shelf Pin Screw w/Rubber Stopper to secure (9) Middle Glass Shelf. **DO NOT OVER TIGHTEN.**

## STEP 9

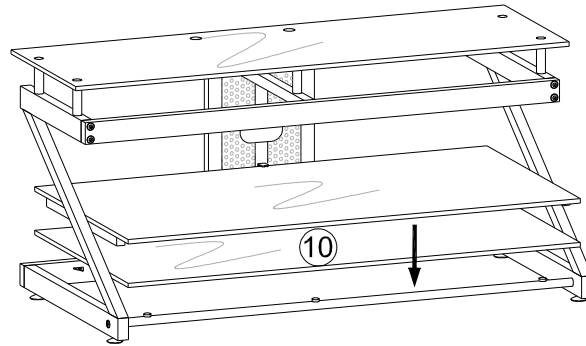

Carefully set (10) Lower Glass Shelf into the BOTTOM position as shown.

**CONGRATULATIONS YOUR Z-LINE DESIGNS ESCALANTE 40" W TV STAND  
IS NOW COMPLETE!**

## DIMENSIONS

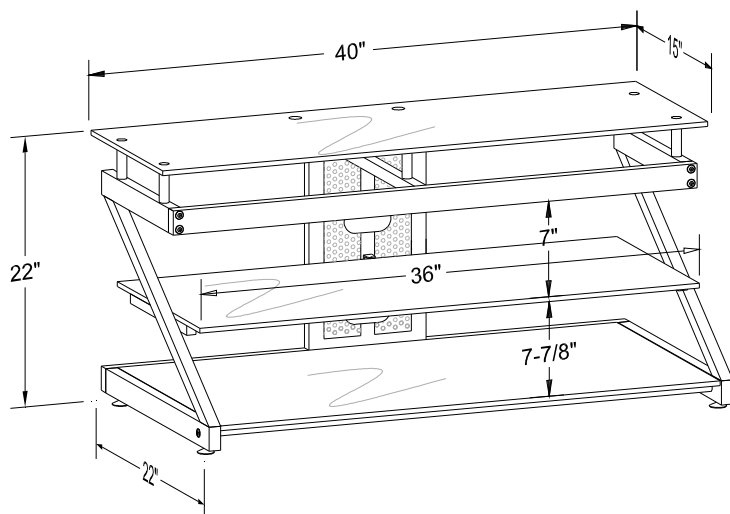

Product Size: 40"(W)x22"(D)x22"(H)

## MAXIMUM WEIGHT CAPACITIES

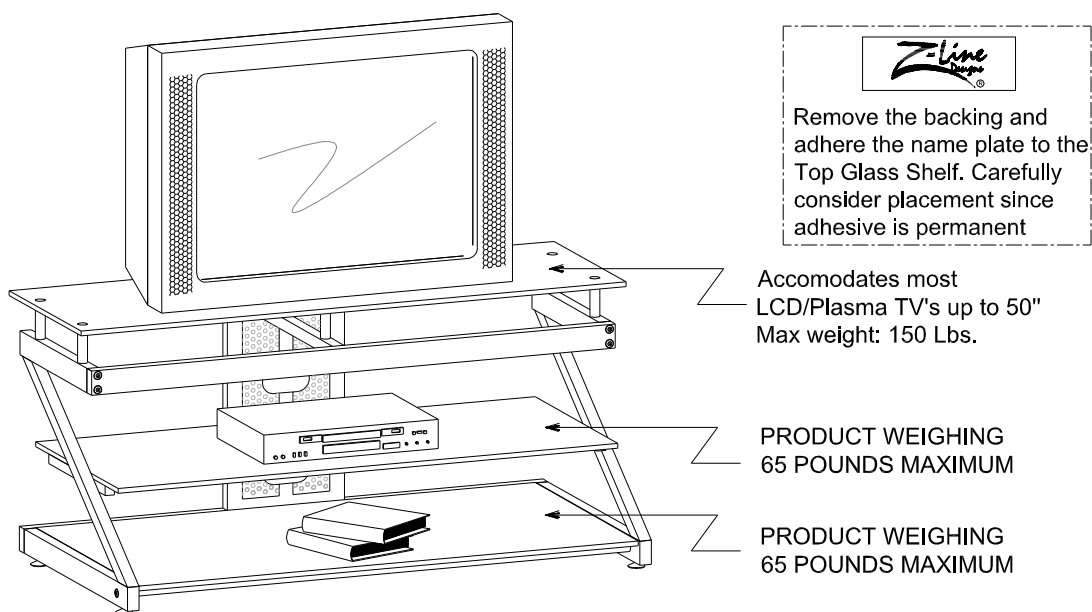

**⚠ CAUTION:** This product is intended to hold the Maximum Weight indicated. Exceeding the Maximum Weight will result in instability and may cause possible injury.

If the glass is chipped or broken stop using the product and consult the manufacturer or supplier.

**\* GLASS CAUTION:**

- DO NOT place very hot or very cold items on the glass surface(s) unless adequately thick table mats are used to prevent such items from coming into contact with the glass.
- DO NOT sit or stand on the glass surface(s).
- DO NOT use the glass as a chopping surface.
- DO NOT strike the glass with hard or pointed items.
- When cleaning the glass, use a liquid glass surface cleanser and a soft cloth; DO NOT use harsh powders or any other abrasive substances as they will scratch the glass.



Creating beauty, Manufacturing great value!



## Limited Lifetime Warranty

Thank you for purchasing a Z-Line Designs product. We promise to repair or replace any Z-Line Designs product or component that may have any defects in material or workmanship for as long as you, the original purchaser, own it. This warranty is subject to the provisions below. Z-Line Designs' sole obligation and purchasers' exclusive remedy pursuant to these warranties are limited to replacement at Z-Line Designs sole discretion. There are no other warranties except as expressly set forth below, either expressed or implied, including any warranty of merchantability for any particular purpose.

The word "defects" in this warranty is defined as imperfections that impair the service, function or effectiveness of the product.

### **FIVE YEARS:**

Glides, casters and user-adjustable work surface mechanisms, laminates, veneer finishes, and other materials which cover your Z-Line Designs product.

### **INFORMATION ON COLOR VARIATIONS & FINISHES:**

Some natural variations occurring in wood or other natural materials are inherent to their character, and thus can not be avoided. Therefore they are not considered to be defects. Z-Line Designs does not warrant the color-fastness or matching of colors, grains, textures or other such materials. Customers' own materials selected by and used at the request of a user are therefore not warranted by Z-Line Designs.

### **LIMITATIONS INVOLVING MATERIALS & COMPONENTS:**

The materials and all components listed below are covered according to the following schedule from the date of sale to the original purchaser.

### **EXCLUSIONS:**

This warranty does not apply to: damage caused by the carrier, modifications to the product, or attachments to the product not approved by Z-Line Designs, non-standard materials selected by and used at the request of a user, and products that were not installed, used or maintained in accordance with product instructions and warnings. Nor shall Z-Line Designs have any responsibility for incidental or consequential damages resulting from the breach of this Warranty, including but not limited to inconvenience, rental or purchase of replacement products, loss of profits or commercial loss. Some states do not allow the exclusion or limitation of incidental or consequential damages so the above limitation or exclusion may not apply to you. This warranty gives you specific legal rights and you may also have other rights, which may vary from state to state. This warranty applies only to products sold within the United States of America and the Commonwealth of Canada.

### **TO OBTAIN SERVICE FROM THIS WARRANTY:**

Your Z-Line Designs' dealer is our mutual partner in supporting your warranty requests. By following the procedures instructed below, you are assured that you will receive the best level of customer service guaranteed.

- A) Please contact the local Dealer from whom you originally purchased within 30 days (unless otherwise noted by the Dealer) of discovery of the defect. Prepare to confirm that you are the original purchaser of the product and provide necessary product information, such as serial number(s)/ UPC number(s) from the product in question.
- B) The Dealer will gather all the pertinent information required regarding your claim(s), inspect the product and thus contact a Z-Line Designs Customer Service Representative. (Please allow a reasonable amount of time for inspection, review, and response to Dealer.
- C) If the Z-Line Designs Dealer confirms that the product in review is eligible under the warranty conditions as stated above, the customer service representative or another representative of the Company will determine whether to provide replacement parts, or authorize other arrangements at the sole discretion of the vendor, Z-Line Designs. No assembly/labor is included in this warranty.

### **TO CONTACT CUSTOMER SERVICE:**

Our knowledgeable Service Representatives are ready to assist you in the case this warranty applies to you. Please be prepared to explain the defect in detail, model/style number, date and location of purchase, your name, address, phone number and have your original sales receipt.

Please contact us Monday-Friday (except all major holidays) at:

Toll Free 1-888-736-2141 from 7:00 am – 3:30 pm (Pacific Standard Time) OR Email us: [customerservice@z-linedesigns.com](mailto:customerservice@z-linedesigns.com)

**OR**

Contact your local dealer from whom you originally purchased the product in question.