

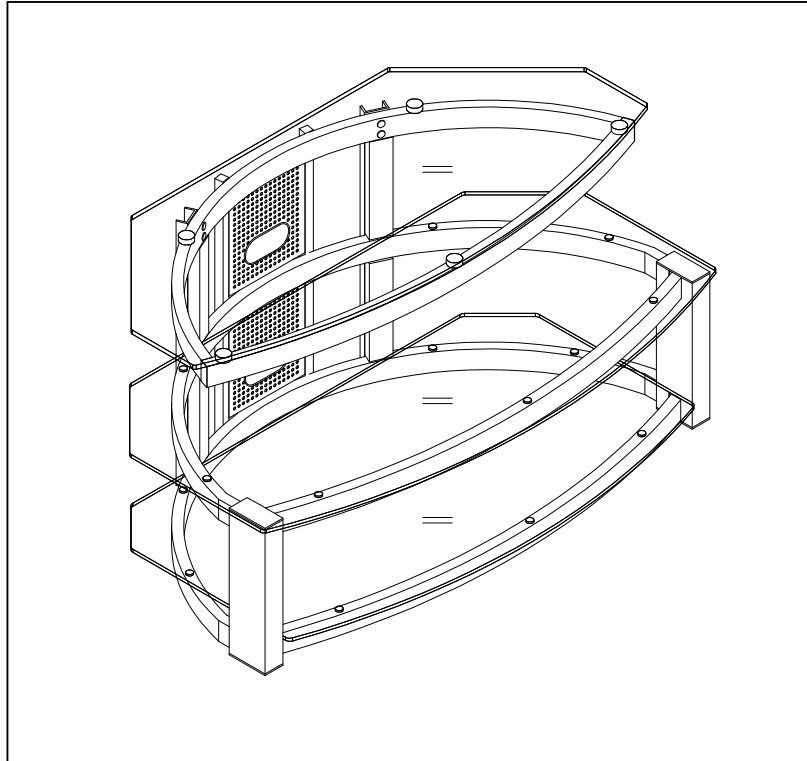

## Ellison Bay TV Stand

**ZLN # ZL3174-RSU-R**



**⚠ DO NOT return to the store if parts are missing or damaged.**

For Parts Replacements and Inquiries, please call us Toll-Free 1-888-736-2141 or E-mail

[CustomerService@Z-LineDesigns.com](mailto:CustomerService@Z-LineDesigns.com).











To ensure a timely delivery, please include the following:

1. Full Name
2. Physical Address (Our primary carrier, FedEx, will NOT deliver to P.O. Boxes)
3. Phone Number
4. QC Number: KT \_\_\_\_\_
5. ZLN Number: ZL3174-RSU-R
6. Part Number(s) or Letter(s)
7. Quantity
8. We also request that you please provide a brief description of the reason for your request.

**Our Customer Service Representatives will be available to assist you Monday – Friday 7:00 am to 3:30 pm Pacific Standard Time (Except Holidays).**

# HARDWARE IDENTIFICATION

**Before you begin:** Open, identify, and count all parts prior to assembly. Lay out on non-abrasive surface.

A		6x57x10mm FLAT HEAD ALLEN BOLT (ABFH65710BL)	8 PCS
B		6x25x10mm ALLEN BOLT (AB62510BL)	6 PCS
C		6x14x10mm ALLEN BOLT (AB61410BL)	8 PCS
D		6x45x12mm ALLEN BOLT (AB64512BL)	4 PCS
E		LEG END CAP	4 PCS
F		BACK PANEL END CAP	4 PCS
G		PLASTIC GLASS SUPPORT	14 PCS
H		PLASTIC BOTTOM SUPPORT	2 PCS
I		4mm ALLEN WRENCH (AW4BL)	1 PC
J		NAME PLATE	1 PC
K		TOP FRAME END CAP	2 PCS

\*Extra hardware is enclosed for your convenience.

# PARTS IDENTIFICATION

①A		TOP FRAME	1 PC
②A		LOWER FRAME	2 PCS
③		FRONT LEG	2 PCS
④		BACK LEG	2 PCS
⑤		BACK PANEL	1 PC
⑥		TOP GLASS SHELF	1 PC
⑦		MIDDLE GLASS SHELF	1 PC
⑧		BOTTOM GLASS SHELF	1 PC

# ASSEMBLY INSTRUCTION

## STEP 1

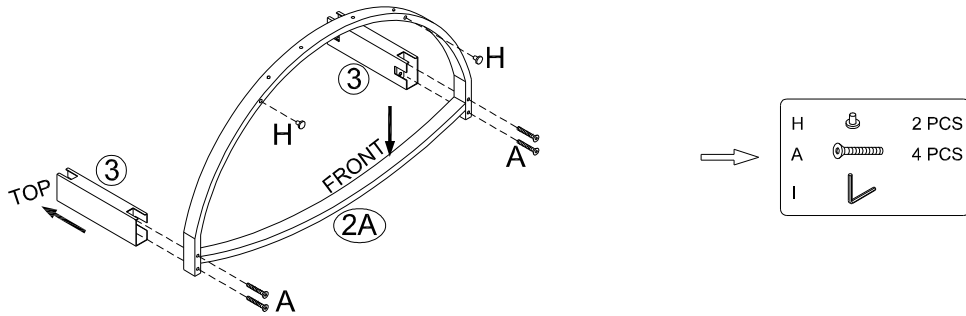

**DO NOT FULLY TIGHTEN ALLEN BOLTS UNTIL THE END OF STEP 4.**

1. Position (2A) Lower Frame laying on its FRONT with the BOTTOM facing TOWARD you as shown.
2. Connect (3) Front Legs to (2A) Lower Frame and attach with (A) 6 x 57 x 10mm Flat Head Allen Bolts.
3. Insert (H) Plastic Bottom Supports into the holes provided on (2A) Lower Frame and stand Unit UPRIGHT for the next step.

## STEP 2

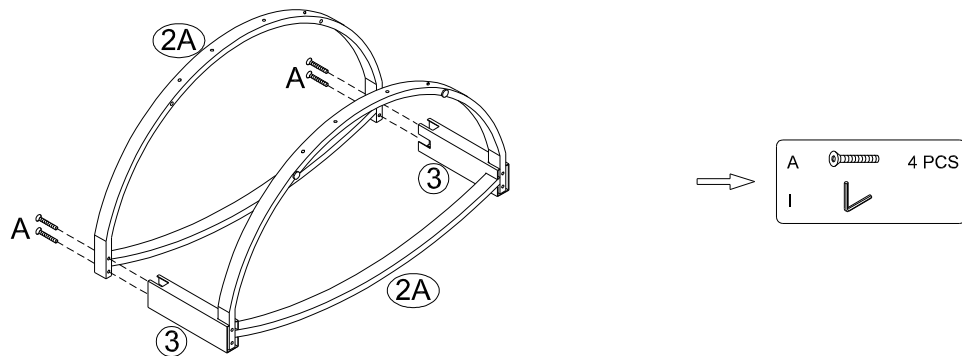

**DO NOT FULLY TIGHTEN ALLEN BOLTS UNTIL THE END OF STEP 4.**

Set (2A) Lower Frame into position and attach with (A) 6 x 57 x 10mm Flat Head Allen Bolts as shown.

## STEP 3

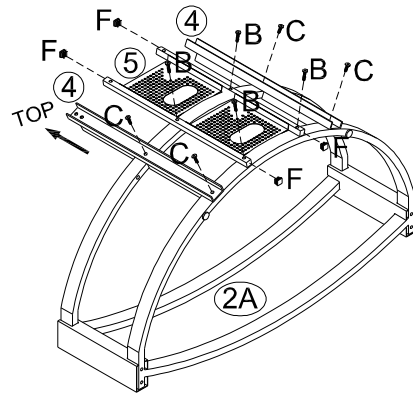

F		4 PCS
B		4 PCS
C		4 PCS
I		

**DO NOT FULLY TIGHTEN ALLEN BOLTS UNTIL THE END OF STEP 4.**

1. Connect (4) Back Legs to the OUTERMOST holes located on (2A) Lower Frames with (C) 6 x 14 x 10mm Allen Bolts.
2. Now connect (5) Back Panel to the CENTER holes located on (2A) Lower Frames with (B) 6 x 25 x 10mm Allen Bolts.
3. Attach (F) Back Panel End Caps to the TOP and BOTTOM of (5) Back Panel as shown.

## STEP 4

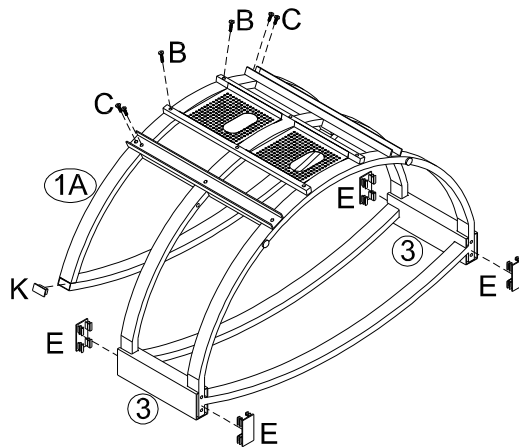

B		2 PCS
C		4 PCS
E		4 PCS
I		
K		2 PCS

1. Attach (1A) Top Frame to (4) Back Legs with (C) 6 x 14 x 10mm Allen Bolts and (5) Back Panel with (B) 6 x 25 x 10mm Allen Bolts.

### **2. TIGHTEN ALL ALLEN BOLTS AT THIS TIME.**

3. Once all Allen Bolts have been tightened, attach (E) Leg End Caps to the TOPS and BOTTOMS of (3) Front Legs, and attach (K) Top Frame End Caps to the side of (1A) Top Frame.

## STEP 5

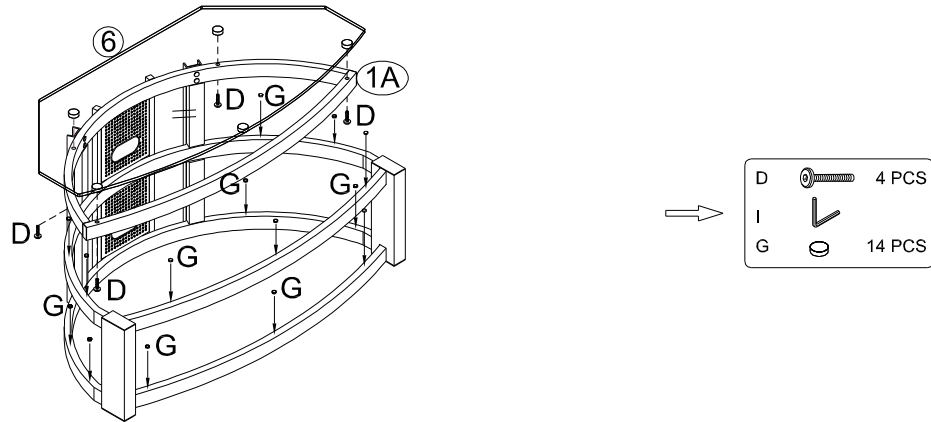

1. Carefully set (6) Top Glass Shelf into place and secure to (1A) Top Frame with (D) 6 x 45 x 12mm Allen Bolts, **TIGHTENING FULLY.**
2. Now adhere (G) Plastic Glass Supports to (2A) Lower Frames in the positions shown.

## STEP 6

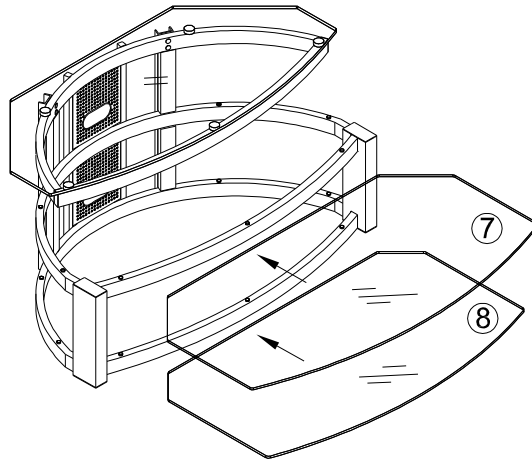

Carefully slide (7) Middle Glass Shelf and (8) Bottom Glass Shelf in place as shown.

**CONGRATULATIONS, YOUR Z-LINE DESIGNS ELLISON BAY TV STAND IS NOW COMPLETE!**

## DIMENSIONS

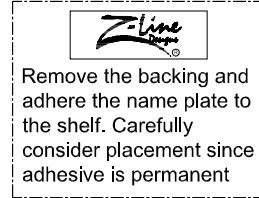
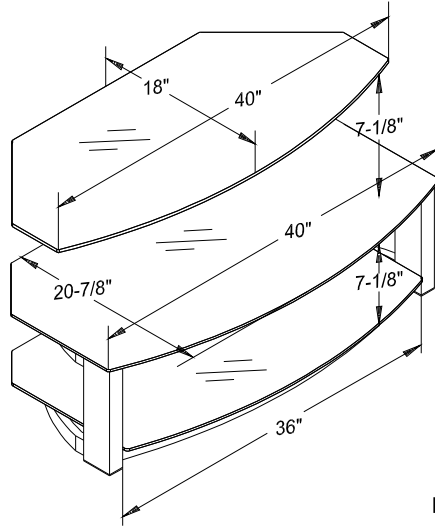

Product Size: 40"(W)x24"(D)x21"(H)

## MAXIMUM WEIGHT CAPACITIES

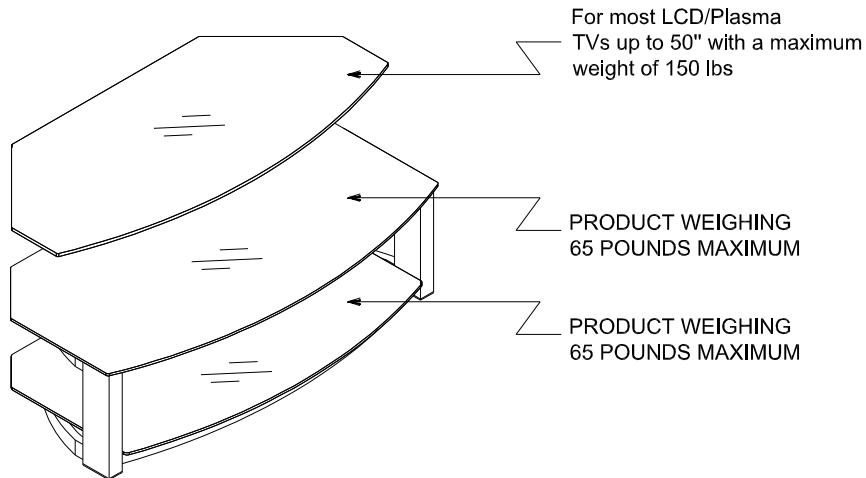

**⚠ CAUTION:** This product is intended to hold the Maximum Weight (EVENLY DISTRIBUTED) indicated. Exceeding the Maximum Weight will result in instability and may cause possible injury.

If the glass is chipped or broken stop using the product and consult the manufacturer or supplier.

### \* GLASS CAUTION:

- DO NOT place very hot or very cold items on the glass surface(s) unless adequately thick table mats are used to prevent such items from coming into contact with the glass.
- DO NOT sit or stand on the glass surface(s).
- DO NOT use the glass as a chopping surface.
- DO NOT strike the glass with hard or pointed items.
- When cleaning the glass, use a liquid glass surface cleanser and a soft cloth; DO NOT use harsh powders or any other abrasive substances as they will scratch the glass.



Creating beauty, Manufacturing great value!



## Limited Lifetime Warranty

Thank you for purchasing a Z-Line Designs product. We promise to repair or replace any Z-Line Designs product or component that may have any defects in material or workmanship for as long as you, the original purchaser, own it. This warranty is subject to the provisions below. Z-Line Designs' sole obligation and purchasers' exclusive remedy pursuant to these warranties are limited to replacement at Z-Line Designs sole discretion. There are no other warranties except as expressly set forth below, either expressed or implied, including any warranty of merchantability for any particular purpose.

The word "defects" in this warranty is defined as imperfections that impair the service, function or effectiveness of the product.

### **FIVE YEARS:**

Glides, casters and user-adjustable work surface mechanisms, laminates, veneer finishes, and other materials which cover your Z-Line Designs product.

### **INFORMATION ON COLOR VARIATIONS & FINISHES:**

Some natural variations occurring in wood or other natural materials are inherent to their character, and thus can not be avoided. Therefore they are not considered to be defects. Z-Line Designs does not warrant the color-fastness or matching of colors, grains, textures or other such materials. Customers' own materials selected by and used at the request of a user are therefore not warranted by Z-Line Designs.

### **LIMITATIONS INVOLVING MATERIALS & COMPONENTS:**

The materials and all components listed below are covered according to the following schedule from the date of sale to the original purchaser.

### **EXCLUSIONS:**

This warranty does not apply to: damage caused by the carrier, modifications to the product, or attachments to the product not approved by Z-Line Designs, non-standard materials selected by and used at the request of a user, and products that were not installed, used or maintained in accordance with product instructions and warnings. Nor shall Z-Line Designs have any responsibility for incidental or consequential damages resulting from the breach of this Warranty, including but not limited to inconvenience, rental or purchase of replacement products, loss of profits or commercial loss. Some states do not allow the exclusion or limitation of incidental or consequential damages so the above limitation or exclusion may not apply to you. This warranty gives you specific legal rights and you may also have other rights, which may vary from state to state. This warranty applies only to products sold within the United States of America and the Commonwealth of Canada.

### **TO OBTAIN SERVICE FROM THIS WARRANTY:**

Your Z-Line Designs' dealer is our mutual partner in supporting your warranty requests. By following the procedures instructed below, you are assured that you will receive the best level of customer service guaranteed.

- A) Please contact the local Dealer from whom you originally purchased within 30 days (unless otherwise noted by the Dealer) of discovery of the defect. Prepare to confirm that you are the original purchaser of the product and provide necessary product information, such as serial number(s)/ UPC number(s) from the product in question.
- B) The Dealer will gather all the pertinent information required regarding your claim(s), inspect the product and thus contact a Z-Line Designs Customer Service Representative. (Please allow a reasonable amount of time for inspection, review, and response to Dealer.
- C) If the Z-Line Designs Dealer confirms that the product in review is eligible under the warranty conditions as stated above, the customer service representative or another representative of the Company will determine whether to provide replacement parts, or authorize other arrangements at the sole discretion of the vendor, Z-Line Designs. No assembly/labor is included in this warranty.

### **TO CONTACT CUSTOMER SERVICE:**

Our knowledgeable Service Representatives are ready to assist you in the case this warranty applies to you. Please be prepared to explain the defect in detail, model/style number, date and location of purchase, your name, address, phone number and have your original sales receipt.

Please contact us Monday-Friday (except all major holidays) at:

Toll Free 1-888-736-2141 from 7:00 am – 3:30 pm (Pacific Standard Time) OR Email us: [customerservice@z-linedesigns.com](mailto:customerservice@z-linedesigns.com)

**OR**

Contact your local dealer from whom you originally purchased the product in question.