

Installation Instructions

Aero W800/W1200 Wall Mount for LCD-TFT Flat Panel Displays by Draper

Important!

- ① Make sure there is no damage to the product prior to installation. Should any damage be evident, please contact your supplier.
- ② Check that all parts are included in the package before mounting the product.
- ③ It is the installer's responsibility to ensure that the product is correctly mounted to the foundation and that screws suitable for the foundation are used.
- ④ Screws optimized according to type of foundation are not included.
- ⑤ Ensure that all screws and bolts are securely tightened before the product is allowed to bear the full weight of the display.
- ⑥ The tilting mechanism can support a maximum weight of 22 lbs; the column can support a maximum of 88 lbs. **Important! this depends on the surface and the type of screws used in the mounting process.**

Hardware/Parts List

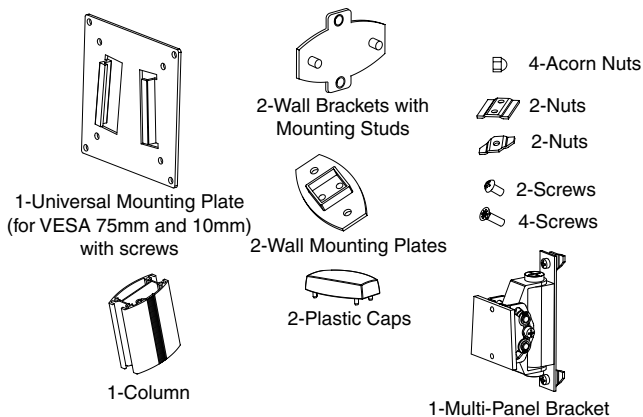

Installation

- ① The wall mounting plate has been pre-mounted on the column. If you wish to change the position, loosen the screws, adjust the position of the mounting plate and re-tighten the screws (see Fig. 1).
- ② Using wall brackets with mounting studs, mark the locations of holes with a pencil and drill holes in the wall where the product is to be mounted. Use a spirit level.
- ③ Mount wall brackets with mounting studs with screws suitable for the type of foundation (not included).
- ④ Attach wall mounting plates to mounting studs (see Fig. 2) and secure with acorn nuts.
- ⑤ Mount the multi-panel bracket (see Fig. 1) and other optional features, if applicable, to the column (see separate instructions included with optional equipment). Make sure that the narrower end of the tilt plate is pointing upwards. The stiffness of the tilt can be adjusted using the two screws at the side of the tilt plate.
- ⑥ Attach the plastic caps.
- ⑦ Mount the universal mounting plate to the back of the screen (see Fig. 3) and attach it to the tilt plate. The narrower end of the universal plate should be pointing upwards. Tighten the safety screw. The universal mounting plate can be mounted to the LCD-TFT display to allow either portrait or landscape orientation.
- ⑧ Place cables behind the rubber strip inside the column.

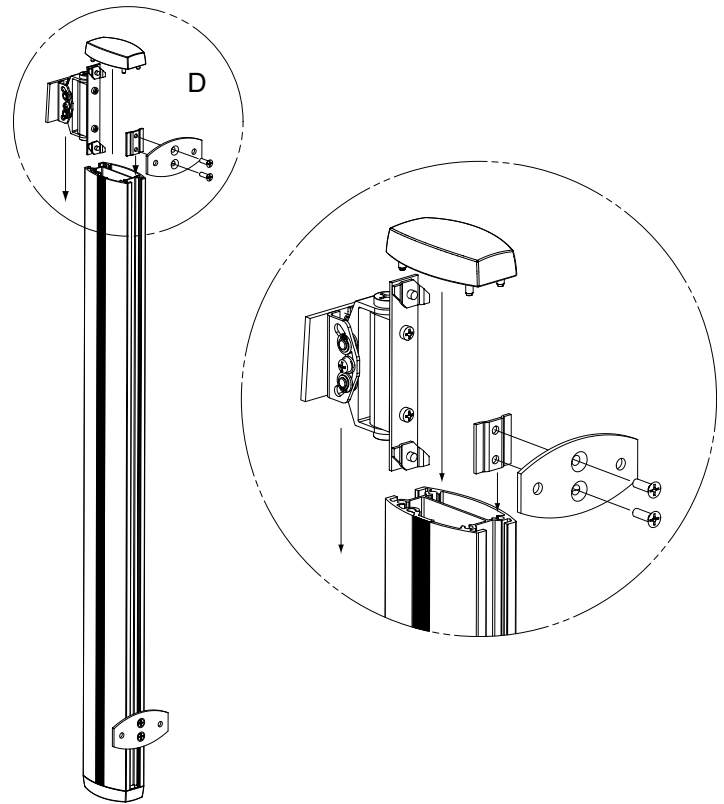

Figure 1

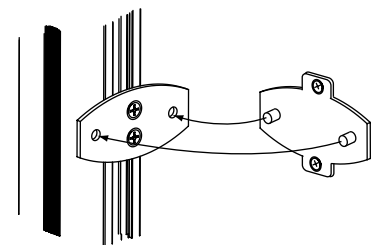

Figure 2

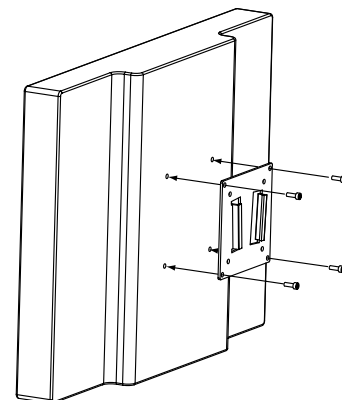

Figure 3

DRAPER

Dimensions

W800

W1200

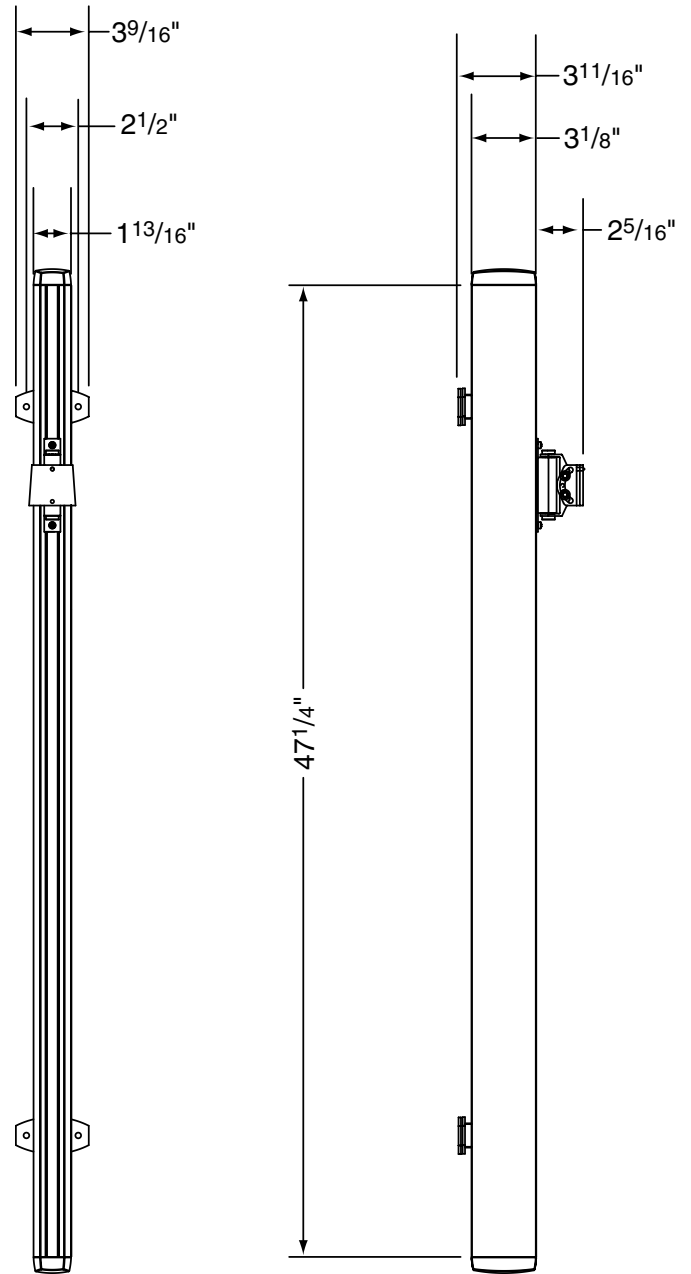
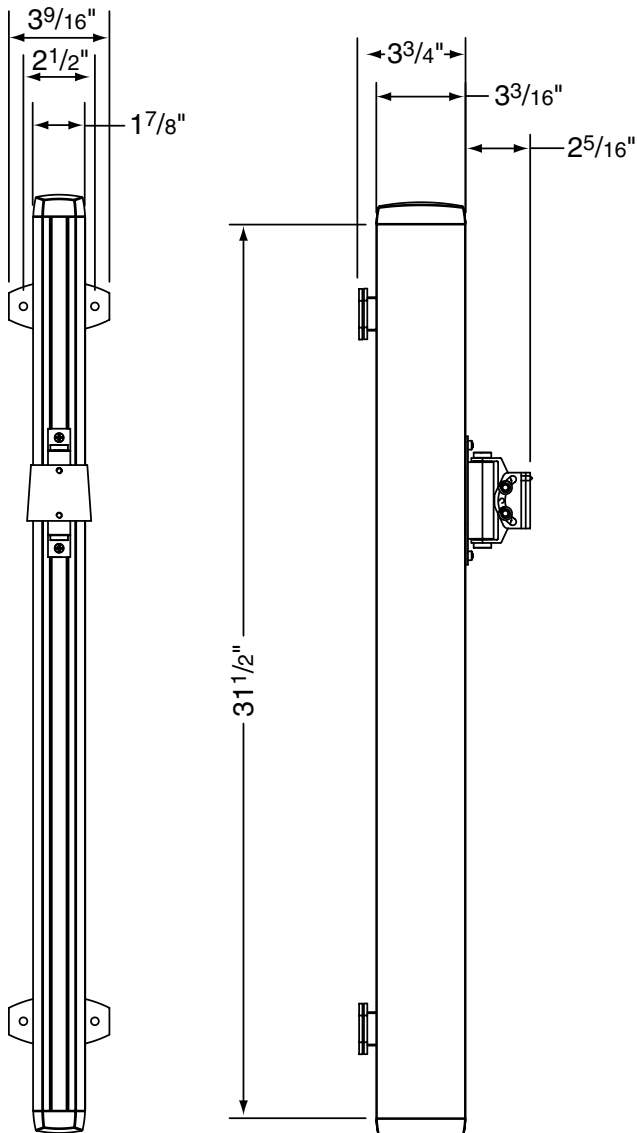

Made in Sweden by sms safe brackets ab,
a wholly-owned subsidiary of Draper, Inc.