

Installation Instructions

Aero Accuset Adjustable Mount for LCD/DLP Projectors by Draper

Caution

- ① Installer must make sure Aero Accuset Mount for LCD/DLP Projectors is positively and securely attached, and appropriate fasteners are used.
- ② Before installing, check to make sure all parts of the mount are there.
- ③ Assembly hardware is included; fasteners for attaching mount to ceiling are not included.
- ④ Make sure all screws and bolts are tightened before allowing mount to bear the full weight of the projector.
- ⑤ Mount projector before hooking up to electrical and other cables.
- ⑥ When making adjustments, make sure projector is firmly supported.
- ⑦ All assembly screws require Metric Allen wrench (included).

Aero Accuset Adjustable—Hardware and Parts

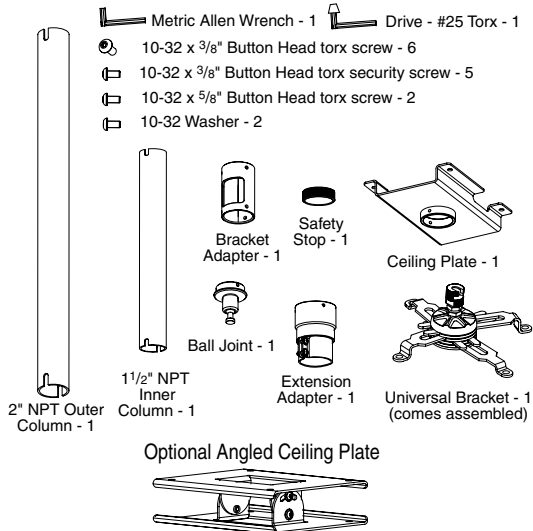

Installation

- ① Screw Outer Column into Ceiling Plate (see Fig. 1).
- ② Attach Positive Stop to upper end of Inner Column, then slide Inner Column down through Extension Adapter. Tighten Extension Adapter using two 10-32 x 5/8" torx screws and #10 washers.
- ③ Install Extension Adapter and Inner Column assembly to Outer Column. Secure with one 10-32 x 5/8" torx screw. For increased security, replace the standard screw with a security screw (provided).
- ④ Attach Bracket Adapter and Ball Joint Assembly to Inner Column and secure with provided screw (see Fig. 1). For increased security, replace the standard screw with a security screw (provided).

Please Note: For additional security, you can remove the three standard screws holding the Ball Joint in the Bracket Adapter, and replace them with provided security screws.

- ⑤ Use mounting plate to mark ceiling (see Fig. 2).
- ⑥ If appropriate, run wiring down through pipe and out through opening in Bracket Adapter.
- ⑦ Attach plate to ceiling. If using optional Angled Mounting Plate, attach Ceiling Mounting Plate to Angled Mounting Plate using 1/4"-20 x 5/8" long hex head screws (provided), then attach Angled Ceiling Mounting Plate to ceiling (hardware for ceiling attachment not included).
- ⑧ Install Aero Universal Projector Bracket on projector if applicable (see separate instructions). Then, attach bracket and projector to Aero Accuset ball joint. Adjust as necessary (see Fig. 3).

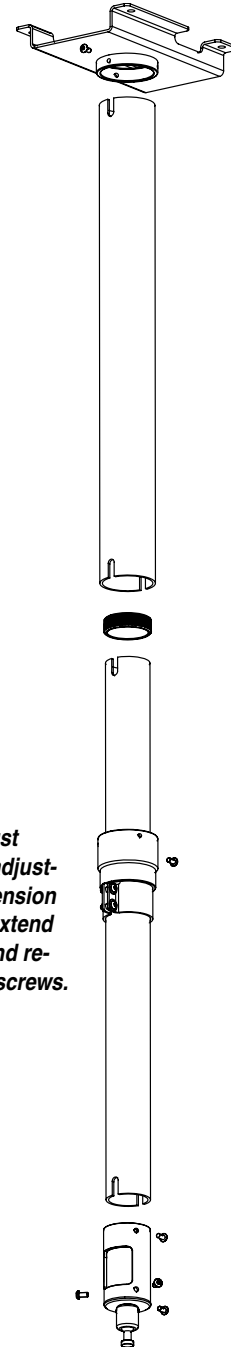

Figure 1

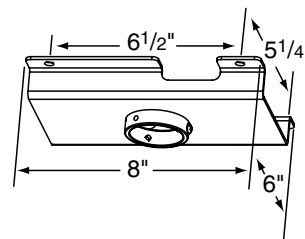

Figure 2

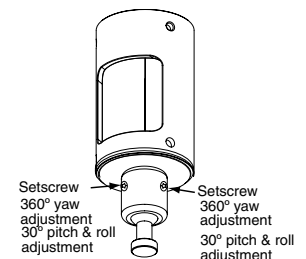

Figure 3

Please note: To adjust height, loosen two adjustment screws in Extension Adapter, retract or extend the inner column, and re-tighten adjustment screws.

DRAPER

411 S. Pearl St., Spiceland, IN 47385 USA ■ 765-987-7999 ■ fax 765-987-7142
e-mail draper@draperinc.com ■ www.draperinc.com

Copyright ©2004 Draper Inc. Form AeroAccusetAdjustable_Inst04 Printed in U.S.A.

If you encounter any difficulty installing or servicing your Aero Accuset Mount for LCD/DLP Projectors, call your dealer or Draper, Inc., Spiceland, Indiana, (765) 987-7999; fax (765) 987-7142; or e-mail draper@draperinc.com.

Aero Accuset Adjustable Mount Dimensions

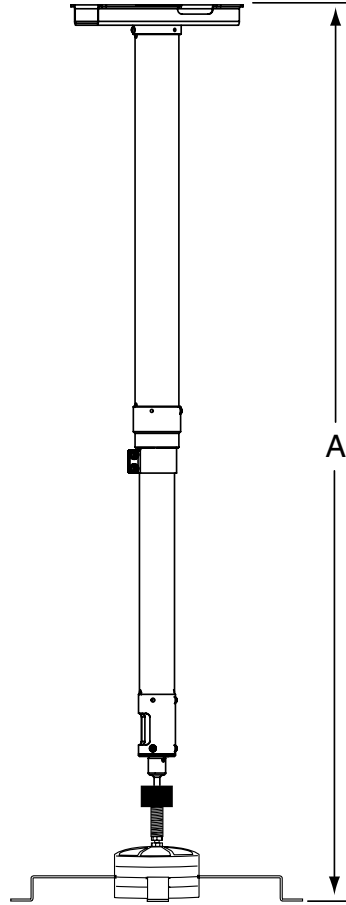

A=Range of Adjustability

15³/₈" - 17³/₄"

21³/₈" - 29³/₄"

29³/₄" - 46³/₄"

44³/₄" - 77³/₄"

57³/₈" - 101³/₄"

69³/₈" - 125³/₄"

81³/₈" - 149³/₄"