

Installation Instructions

Aero W490/W1150 Wall Mounts for Plasma Displays by Draper

Caution

- ① Installer must make sure plasma display mount is positively and securely attached, and that fasteners appropriate to materials are used.
- ② Before installing, check to make sure all parts of the mount are there.
- ③ Assembly hardware is included; fasteners for attaching mount to wall are not included.
- ④ Make sure all screws and bolts are tightened before allowing Mount to bear the full weight of the plasma display.
- ⑤ At least two people are required to assemble and mount this product.
- ⑥ All assembly screws require Allen wrench (included).

Please Note: See page two for a complete hardware and parts list.

- ① Fasten the lower wall fixture inside the aluminum pillar with 4 countersunk M6 x 25 bolts (see Fig. 1).
- ② Push in the side fittings (see Fig. 1).
- ③ Fasten the upper wall fixture inside the aluminum pillar with 4 countersunk M6 x 25 bolts (see Fig. 1).

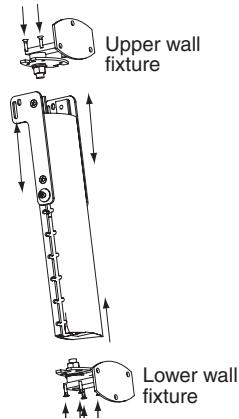

Figure 1

- ④ Mount side fittings at the desired height. Insert M8 x 30 bolts where indicated. Tighten all bolts (see Fig. 2).
- ⑤ PLEASE NOTE: This step requires two people: Use the wall fixtures as a template to mark where to drill holes for the wall screws. Use level to check alignment, drill holes and fasten fixtures to wall.

NOTE: Do not forget to use washers when attaching fixtures.

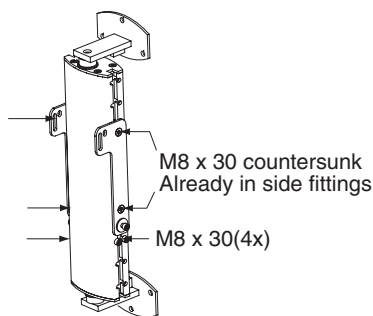

Figure 2

- ⑥ Hook adapter plate onto M8 x 20 screws on side fittings. Make sure washers are tight against the fittings. Fasten screws, making sure that washers are between the plates (see Fig. 3).

Please Note: For tilt, attach in slotted holes. For non-tilt, attach in small hole.

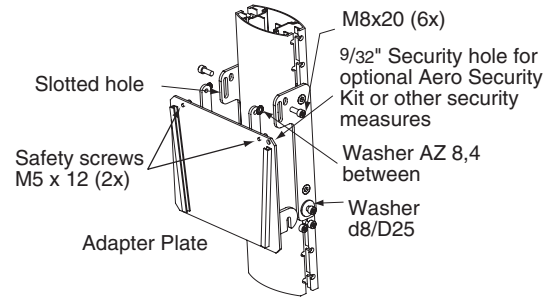

Figure 3

- ⑦ PLEASE NOTE: This step requires two people. Attach universal of plasma-specific bracket to back of plasma display (see Fig. 4). Hook display with bracket onto the adapter plate. Tilt monitor to desired position and re-tighten all screws. Lock the plasma bracket by turning the M5 x 10 screws toward the display. Cover the bolt heads with plastic covers (see Fig. 3).

NOTE: For additional displays, repeat steps 6-7 for each unit.

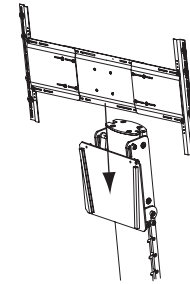

Figure 4

- ⑧ If shelf is provided, slide from top or bottom of column into place on column and place at desired height (see Fig. 5). Slide lock device into place to secure shelf.

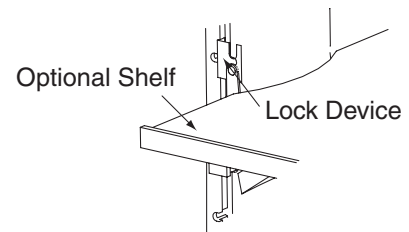
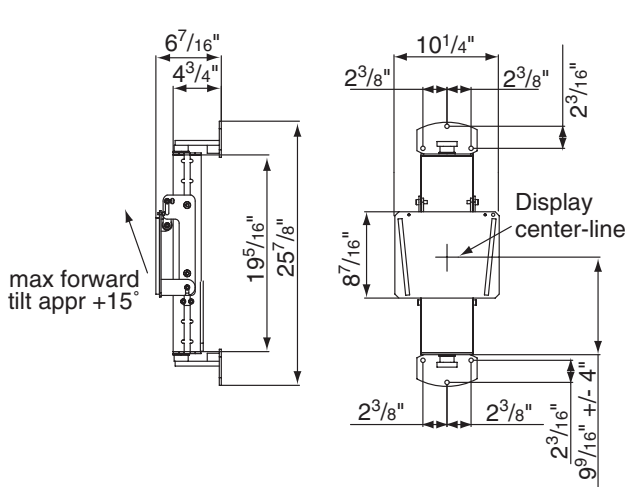

Figure 5

DRAPER

W490 Dimensions



Upper Wall Plate for W490/W1150

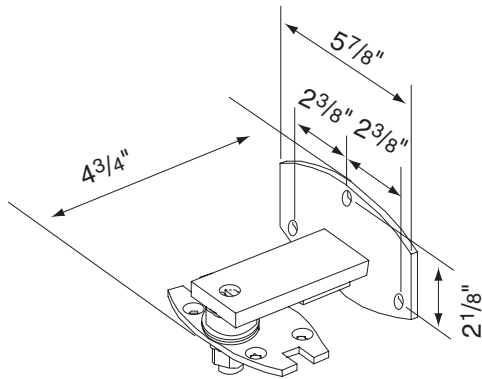

Lower Wall Plate for W490/W1150

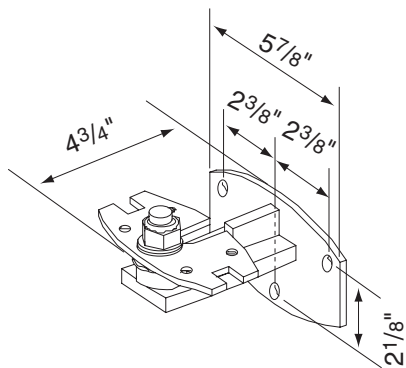

W1150 Dimensions

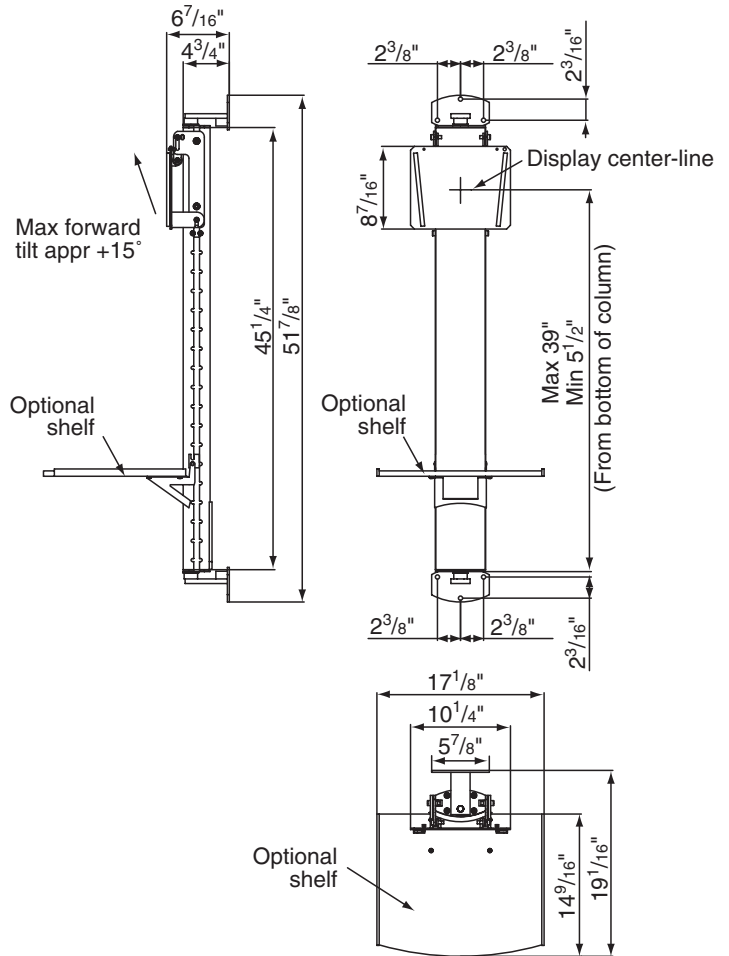

W490-W1150 Parts and Hardware List

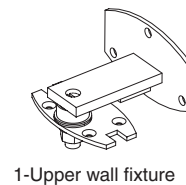
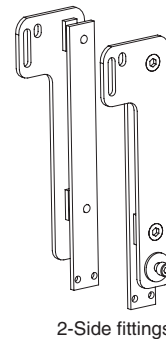
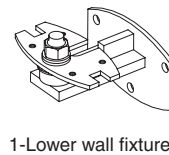
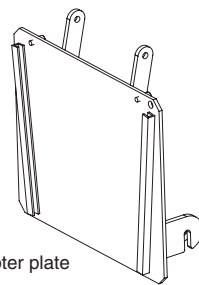
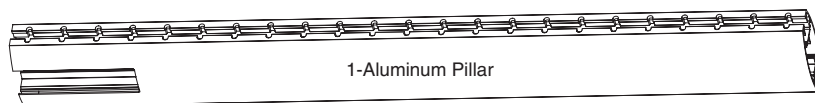

- 8-M6x25 countersunk screws
- 16-Caps
- 2-Allen keys 4,5
- 6-Washers BRB 8,4
- 2-M8x20 screws
- 4-M8x30 screws
- 2-Washers AZ 8,4
- 4-Plastic covers 20x20x1-1,5
- 2-Screws for plug socket

Made in Sweden by sms safe brackets ab, a wholly-owned subsidiary of Draper, Inc.