

CHICAGO FAUCETS



2100 SOUTH CLEARWATER DRIVE
DES PLAINES, ILLINOIS 60018-5999

FITTING NO.

807-665PSH

SUBMITTED MODEL NO.

Last As Long As The Building

JOB NAME

ITEM NO.

SUBMITTED AS SHOWN

SUBMITTED AS NOTED

SEE ATTACHED FOR
SUBMITTED MODIFICATION



ADA COMPLIANT

IS ASSUMED FOR USE OF SUPERCEDED OR VOIDED DATA. (0192-1)

ROUGHING IN DIMENSIONS MAY VARY AND ARE SUBJECT TO CHANGE. NO RESPONSIBILITY

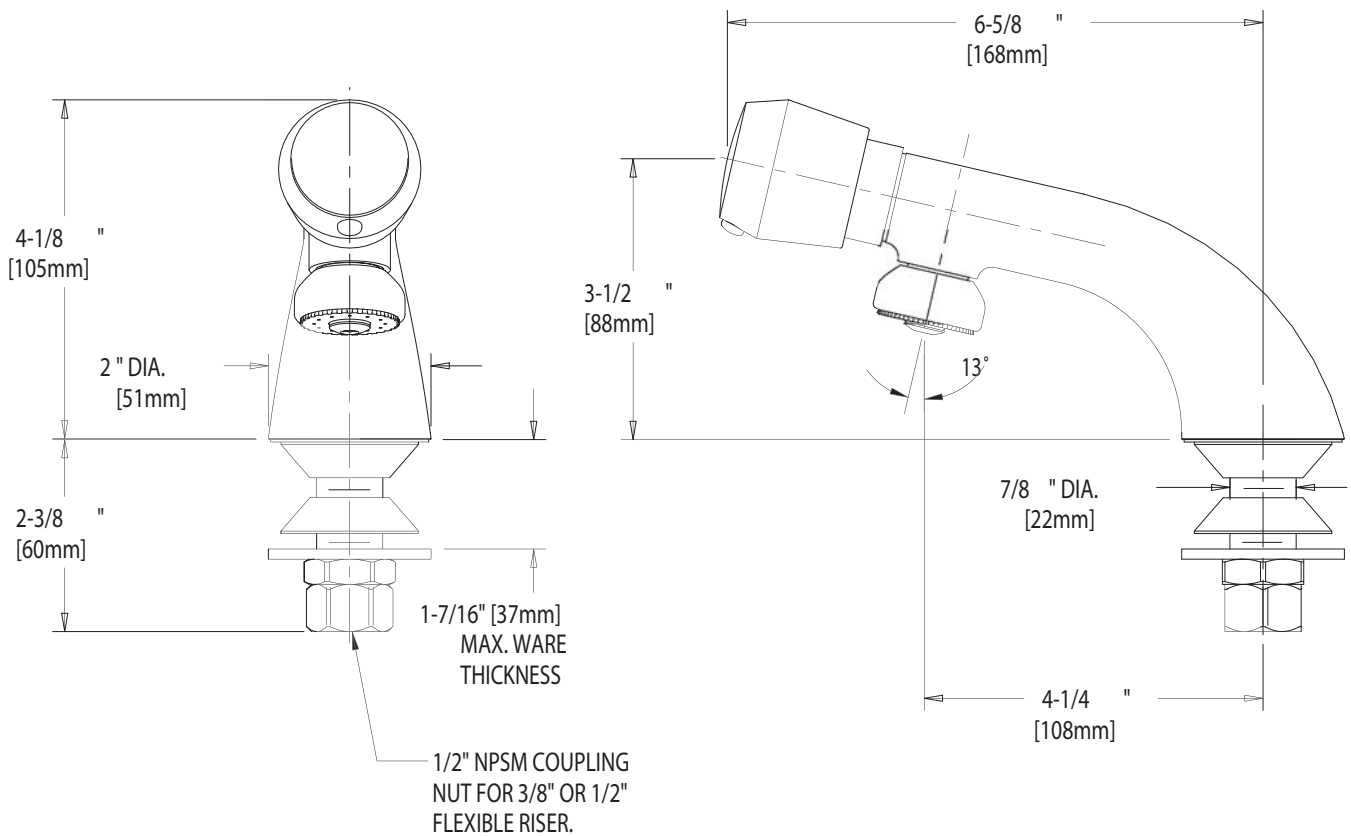

DIMENSIONS IN INCHES AND [MILLIMETERS].

TECHNICAL DATA

- DECK MOUNTED SINGLE WATER INLET FITTING
- 665 INDEXED PUSH BUTTON HANDLE
- MVP METERING VALVE CARTRIDGE
- FINISH: CHROME PLATE

- E15 SPRAY OUTLET
- 2.0 GPM [7.6 L/min.]
- ASME A112.18.1M COMPLIANT
- CSA B125 COMPLIANT

DATE: 05-20-02

BY: SID

CHK'D:

APP'D:

REV: A

807-665PSH