

CHICAGO FAUCETS



2100 SOUTH CLEARWATER DRIVE
DES PLAINES, ILLINOIS 60018-5999

FITTING NO.

404-665

SUBMITTED MODEL NO.

Last As Long As The Building

JOB NAME

ITEM NO.

SUBMITTED AS SHOWN

SUBMITTED AS NOTED

SEE ATTACHED FOR
SUBMITTED MODIFICATION



ADA COMPLIANT

IS ASSUMED FOR USE OF SUPERCEDED OR VOIDED DATA.

ROUGHING IN DIMENSIONS MAY VARY AND ARE SUBJECT TO CHANGE. NO RESPONSIBILITY

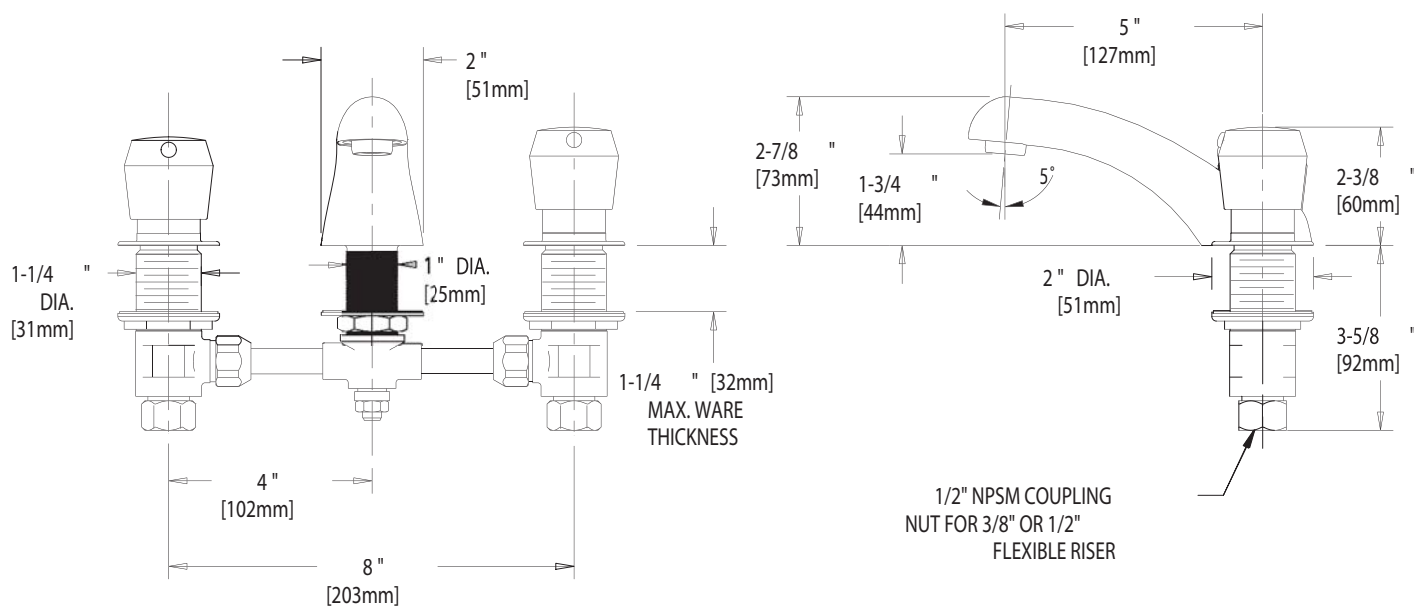

DIMENSIONS IN INCHES AND [MILLIMETERS].

TECHNICAL DATA

- DECK MOUNTED FAUCET
- 5" CAST BRASS SPOUT
- 665 INDEXED PUSH BUTTON HANDLES
- MVP SELF-CLOSING METERING CARTRIDGES
- FINISH: CHROME PLATE

- E12 SOFTFLO AERATOR
- 2.2 GPM [8.3 L/min.] MAXIMUM FLOW RATE
- ASME A112.18.1M COMPLIANT
- CSA B125 COMPLIANT
- NSF 61 COMPLIANT

DATE: 8-26-02

BY: JAR

CHK'D:

APP'D:

REV: A

404-665