

CHICAGO FAUCETS



2100 SOUTH CLEARWATER DRIVE
DES PLAINES, ILLINOIS 60018-5999

Last As Long As The Building

FITTING NO.

1012

SUBMITTED MODEL NO.

JOB NAME

ITEM NO.

SUBMITTED AS SHOWN

SUBMITTED AS NOTED

SEE ATTACHED FOR
SUBMITTED MODIFICATION

IS ASSUMED FOR USE OF SUPERCEDED OR VOIDED DATA.

ROUGHING IN DIMENSIONS MAY VARY AND ARE SUBJECT TO CHANGE. NO RESPONSIBILITY

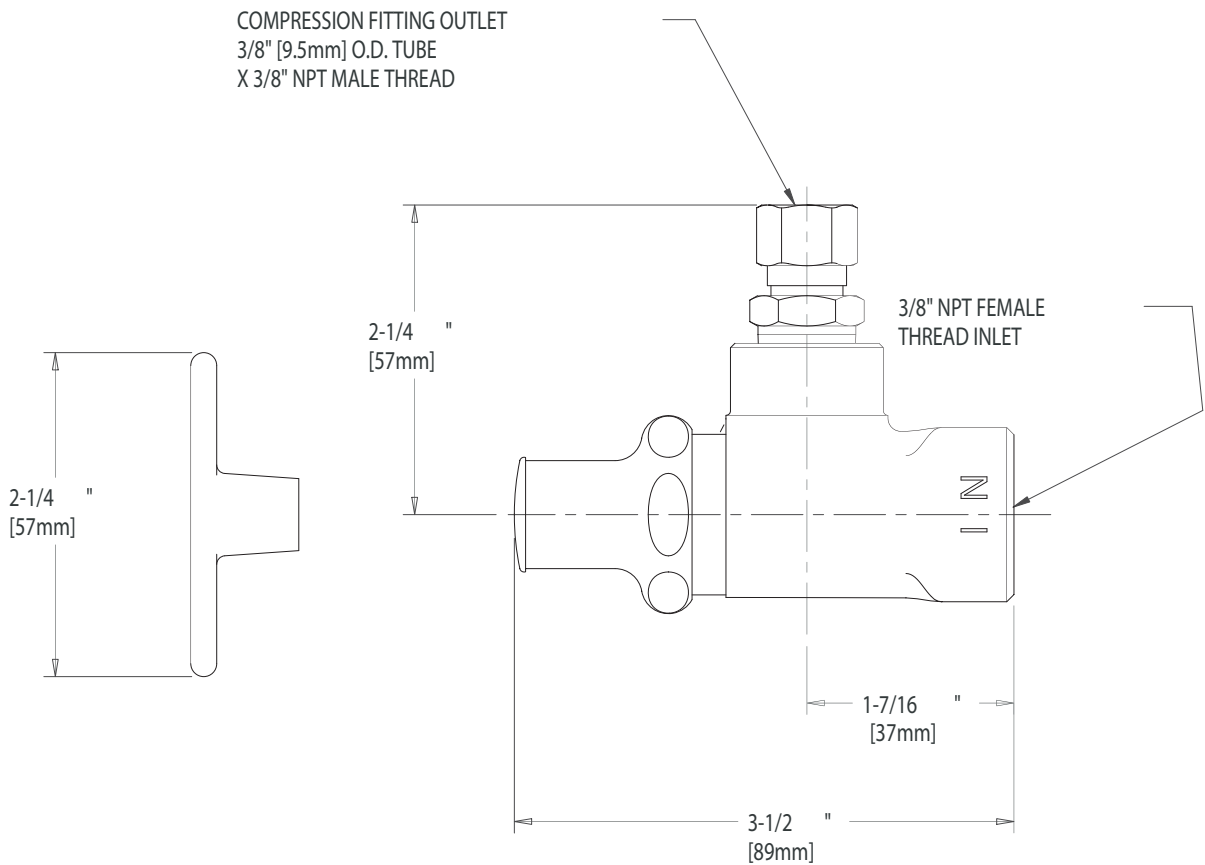

DIMENSIONS IN INCHES AND [MILLIMETERS].

TECHNICAL DATA

- ANGLE STOP FITTING
- 293-6 LOOSE KEY HANDLE
- SLOW COMPRESSION CARTRIDGE
- FINISH: CHROME PLATE

- 3/8" NPT FEMALE INLET
- 3/8" [9.5mm] O.D. COMP. OUTLET
- ASME A112.18.1M COMPLIANT
- CSA B125 COMPLIANT
- NSF 61 COMPLIANT

DATE: 5-20-02

BY: JAR

CHK'D:

APP'D:

REV: A

1012