

# CHICAGO FAUCETS



2100 SOUTH CLEARWATER DRIVE  
DES PLAINES, ILLINOIS 60018-5999

Last As Long As The Building

FITTING NO.

769-LESSHDL

SUBMITTED MODEL NO.

JOB NAME

ITEM NO.

SUBMITTED AS SHOWN

SUBMITTED AS NOTED

SEE ATTACHED FOR  
SUBMITTED MODIFICATION

IS ASSUMED FOR USE OF SUPERCEDED OR VOIDED DATA.

ROUGHING IN DIMENSIONS MAY VARY AND ARE SUBJECT TO CHANGE. NO RESPONSIBILITY

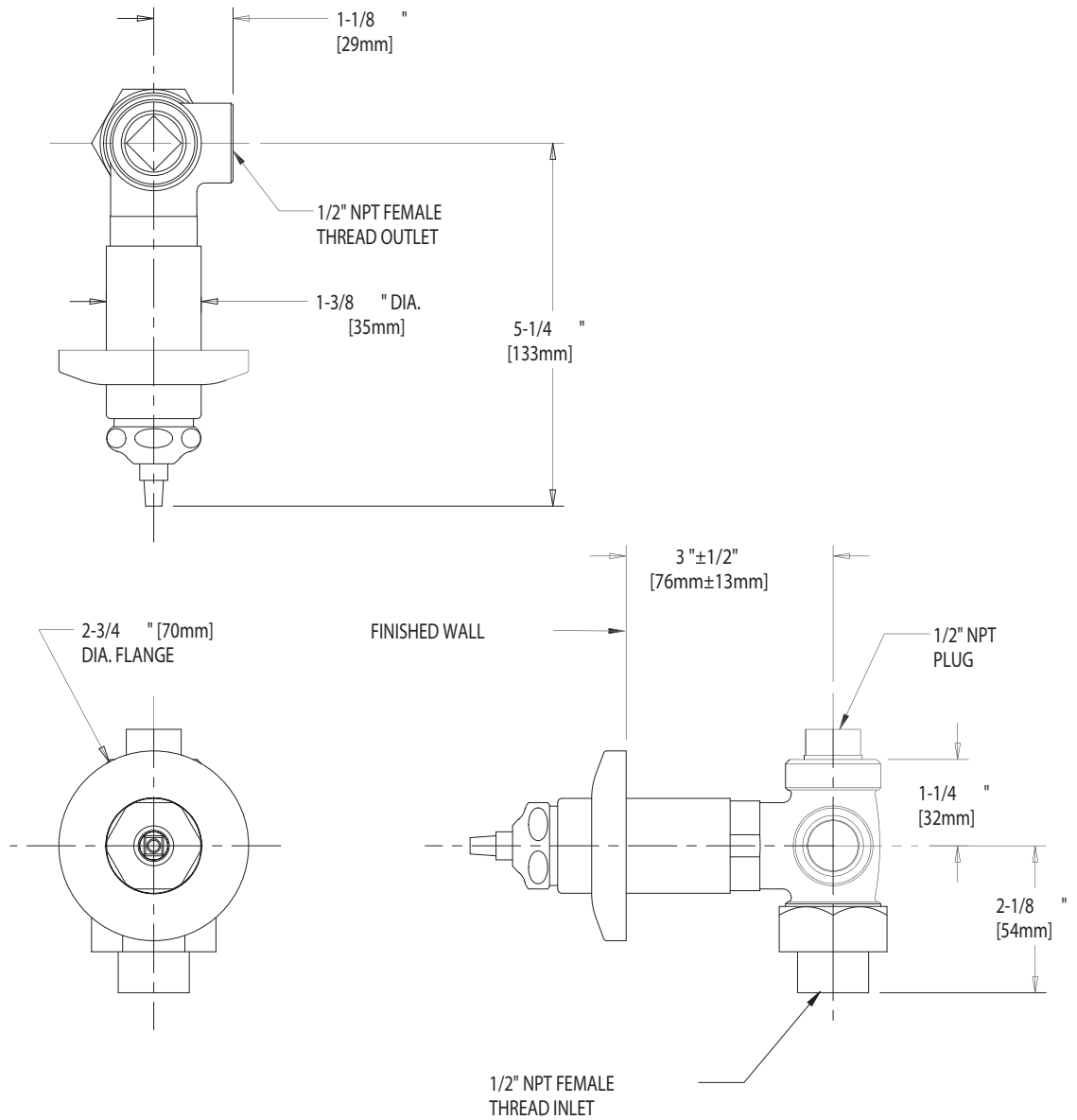

DIMENSIONS IN INCHES AND [MILLIMETERS].

**TECHNICAL DATA**

- CONCEALED ANGLE BYPASS VALVE
- LESS HANDLE
- SLO-COMPRESSION OPERATING CARTRIDGE
- FINISH: CHROME PLATE

- ASME A112.18.1M COMPLIANT
- CSA B125 COMPLIANT

DATE: 12-05-00

BY: SID

CHK'D:

APP'D:

REV: A

769-LESSHDL