

American Standard

COMMERCIAL

EXPOSED YOKE WALL MOUNT UTILITY FAUCET WITH VACUUM BREAKER AND STOPS IN SHANKS

MODEL NUMBER:

- 8341.076 Exposed Yoke Wall-Mount Utility Faucet Vacuum breaker. Stops in shanks. Metal Lever handles. 1/2" NPT female inlets.

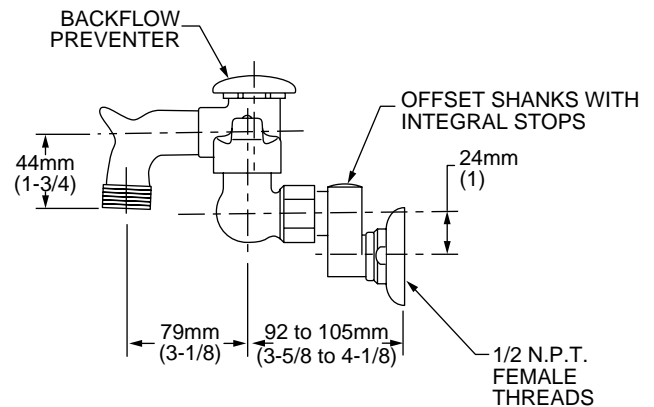
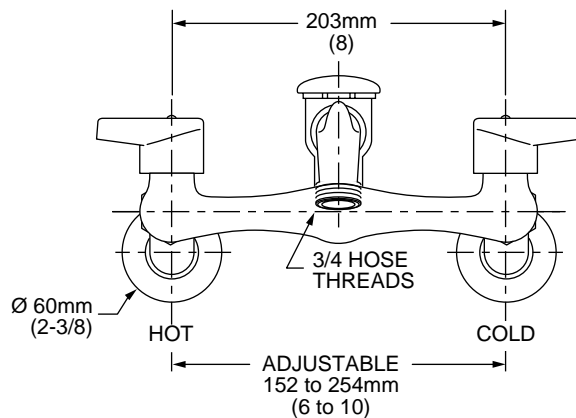
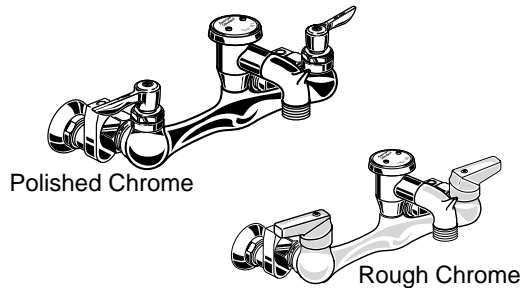

GENERAL DESCRIPTION:

Cast brass body. Metal lever handles with hot and cold indicators. 1/4 turn ceramic disc valve cartridges that are reversible for use on both "hot" and "cold" sides. Vacuum breaker prevents back flow. Offset shanks with integral stops. Spout with bucket hook and threaded hose end. 1/2" female inlets adjustable from 6" to 10".

PRODUCT FEATURES:

Cast Brass Construction: Durable - Excellent in high use applications.

Ceramic Disc Valve Cartridges: Assure a lifetime of drip-free performance.

Offset Shanks with Integral Stops: Permits easy and convenient access. Adjustable rough in from 6 to 10 inches.

Vacuum Breaker: Prevents back flow.

Choice of Finishes: Available in Polished or Rough Chrome.

SUGGESTED SPECIFICATION

Exposed yoke wall-mount utility faucet shall feature a cast brass body and spout with bucket hook and metal lever handles. Shall feature a vacuum breaker and stops in shanks. Shall also feature 1/4 turn washerless ceramic disc valve cartridges. Fitting shall be American Standard Model # 8341.076. ____

American Standard

COMMERCIAL

**EXPOSED YOKE WALL
MOUNT UTILITY FAUCET
WITH VACUUM BREAKER AND STOPS IN SHANKS**

CODES AND STANDARDS

These products meet or exceed the following codes and standards:

- ASME A112.18.1M
- CSA B 125
- ASSE 1001
- ANSI A117.1

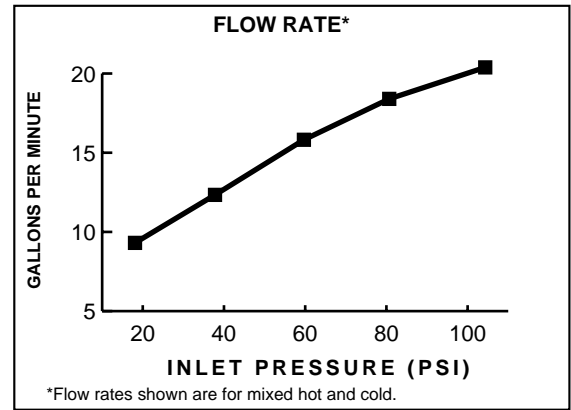

Product Number	Description	Finish Options	
		Polished Chrome 002	Rough Chrome 004
8341.076	Exposed yoke wall-mount utility faucet. Vacuum breaker. Stops in shanks.		

 Meets the American Disabilities Act Guidelines and **ANSI A117.1** Requirements for the physically challenged.